

TP351 Forest Cottage

and TP968 Wavy Slide (Optional purchase)

INSTRUCTIONS FOR ASSEMBLY MAINTENANCE AND USE
PLEASE RETAIN FOR FUTURE REFERENCE.



- Important!** These instructions must be followed for safe assembly and use. Please retain for future reference.
- Important!** Vous devez suivre ces instructions pour que le montage et l'utilisation se fassent en toute sécurité. Veuillez conserver pour référence ultérieure.
- Importante!** Per garantire sicurezza di montaggio ed uso, seguire queste istruzioni e conservarle per futuro riferimento.
- Importante!** Debe seguirse estas instrucciones para un armado y uso seguros. Sírvase conservarlas para consultarlas en el futuro.
- Wichtig!** Diese Anweisung ist für sicheren Aufbau und Gebrauch zu befolgen. Für künftigen Gebrauch aufbewahren.
- Importante!** Para assegurar uma montagem e uma utilização seguras, têm de ser seguidas estas instruções. Guardar para referência futura.



WARNING!

TOY MUST BE ASSEMBLED BY AN ADULT BEFORE USE.
CHILDREN MUST NOT USE THE EQUIPMENT UNTIL PROPERLY INSTALLED.
THIS PRODUCT CONTAINS SMALL PARTS AND IS NOT SUITABLE FOR CHILDREN UNDER 36 MONTHS.
REMOVE ALL PACKAGING BEFORE GIVING TO YOUR CHILDREN.
ONLY FOR DOMESTIC USE. FOR OUTDOOR USE. ADULT SUPERVISION IS REQUIRED.
ANCHORS THAT ARE SUPPLIED WITH THIS PRODUCT MUST BE FITTED BEFORE USE.
THIS PRODUCT IS INTENDED FOR USE BY CHILDREN FROM AGES 3 TO 8 YEARS.
MAXIMUM COMBINED USER WEIGHT 150KGS



**Assembly
Build**

GB

INSTRUCTIONS FOR ASSEMBLY, MAINTENANCE AND USE OF TP TOYS -**Please read carefully and keep all enclosed information for future reference.**

- 1. ASSEMBLY AND SAFETY INFORMATION**
TP toys must be assembled by an adult. They must be erected exactly in accordance with the assembly instructions. Enlisting the aid of a helper will make assembly easier. In order to ensure the correct tensions and to ease assembly, it is important to assemble the product hand tight to begin with. Only when complete, should the fastenings be fully tightened and checked. This pack may contain small parts and is not suitable for children under 36 months. We recommend that you place small parts on a tray, or something similar, to prevent the frustration and disappointment of mistaking them. Please take care during assembly as the manufacturing process can sometimes result in the occasional sharp edge and small pieces of waste metalwork. General instruction to kit/accessory about installation of rope/nets (in relation with the diameter fixed at both ends, length of pending, interaction with other structure. Should there be any missing parts, the toy must not be used until replacement parts have been fitted - contact the TP Customer Services: Email: directsales@tp toys.com
- 2. SITING**
Under no circumstances should any of our toys be positioned on a hard surface such as concrete or asphalt, unless the ground under the toy plus the recommended freespace area is covered with a safety surface. Examples of suitable surfaces are grass, sand or a play surface intended for this use. TP toys should be sited on level ground.
- 3. USAGE**
TP toys are designed and made for use only by children aged between 36 months and 8 years, unless otherwise stated, and must not be used by anybody else. Misuse can result in injury. TP tents must not be walked or climbed upon. Warning only for Domestic use. For outdoor use only.
- 4. SUPERVISION**
Children should always be supervised while they are playing on TP toys and should be instructed not to use the toy in an inappropriate or hazardous manner. We recommend that they do not wear loose-fitting clothing or jewellery that may catch or snag during play. Children should not wear cycle helmets while playing on TP toys. Whilst using this swing seat children must have constant adult supervision.
- 5. WEATHER CONDITIONS**
Special care should be taken as weather conditions change. In particular, outdoor toys can become slippery in wet weather and tongues and lips can stick to metalwork at subzero temperatures. In warmer and sunnier weather, parts can become hot, and the temperature should be regularly checked during play, especially metal parts and slides. If there is any doubt over safety then the toys should not be used. If high wind is expected or forecasted, please ensure that the outdoor toys are either moved to a sheltered position or well secured to the ground or other immovable object. Please store plastic swing accessories indoors if temperature falls below 40°F (4°C).
- 6. WATER PLAY**
Many surfaces can become slippery during water play. Extra caution and supervision is required when combining water (e.g. paddling pools, aqua slides etc.) with other forms of outdoor play.
- 7. MAINTENANCE**
With all toys it is vital that the equipment is checked regularly and often by an adult. The complete toy should be checked at least once a month, and particular attention should be paid to connections and fastenings. If any parts exhibit signs of wear and tear, they may need to be replaced. To replace defective parts in accordance with the manufacturer's instructions. Checks must be carried out at the beginning of the usage season as well as at regular intervals throughout the usage season. Check all nuts and bolts for tightness and tighten when required. Failure to do this may result in the product malfunctioning and causing injury. Children must not be allowed to use the toy until properly installed and checked. Galvanised tubular products may require occasional maintenance. If surface rust appears it should be removed with either a wire brush or coarse sandpaper, and the area treated with a non-toxic paint. Changes to the original toy (for example the adding of an accessory) shall be carried out according to the instructions of the retailer of the original toy.
- 8. FIRE RISKS AND DISPOSAL**
Never allow TP toys to be placed or used near a fire. When it becomes necessary to dispose of your equipment, remove all bolts and disassemble. Store out of the reach of children until it can be properly disposed of. These instructions are issued in the interest of child safety, and we do ask you to follow our advice.

F

INSTRUCTIONS CONCERNANT L'ASSEMBLAGE, L'ENTRETIEN ET L'UTILISATION DE MATÉRIEL**TP Veuillez lire attentivement les instructions suivantes et les conserver à des fins de référence future.**

- 1. ASSEMBLAGE ET SÉCURITÉ**
L'assemblage des équipements/jouets TP doit être uniquement effectué par un adulte. Le montage doit être fait en suivant rigoureusement les étapes des instructions fournies. L'aide d'une seconde personne peut grandement faciliter l'assemblage. Afin d'assurer les tensions correctes et pour faciliter le montage, il est important d'assembler le produit en serrant à la main pour commencer. Ce n'est qu'un fois le montage terminé que les fixations devront être serrées à fond et vérifiées. Veuillez vous assurer que toutes les fixations sont bien serrées avant d'utiliser l'installation. Cet équipement ne convient pas à des enfants de moins de 3 ans car il comporte de petits éléments pouvant être avalés ou inhalés. Afin d'éviter les risques de perte de certaines pièces de taille réduite, il est conseillé de les déposer sur un plateau ou sur un support du même genre. Lors de l'assemblage, il est recommandé de manipuler les pièces avec précaution car celles-ci peuvent présenter des aspérités résultant du procédé de fabrication. S'il manque des pièces, ne pas utiliser le matériel tant que la ou les pièces en question n'ont pas été montées. Service Clients TP: Email directsales@tp toys.com
- 2. INSTALLATION**
Notre matériel ne doit en aucun cas être installé sur des surfaces en dur (béton, asphalte, etc.) à moins que la surface du sol sous le matériel (plus la marge de sécurité recommandée à l'extérieur du périmètre total du matériel) ne soit recouverte d'un revêtement de sécurité. Il est recommandé d'installer le matériel sur de l'herbe ou du sable ou une aire recouverte d'un revêtement de sécurité approprié. Les équipements TP doivent être installés sur une surface plane.
- 3. UTILISATION**
Nos équipements/jouets sont destinés à l'usage familial et ont été conçus, sauf mention spéciale, à l'intention des enfants entre 36 mois et 8 ans; ils ne doivent EN AUCUN CAS être utilisés par d'autres personnes. Nos équipements/jouets sont entièrement sûrs s'ils sont utilisés conformément aux présentes instructions. Il ne faut pas marcher ou grimper sur les tentes "TP".
- 4. SUPERVISION**
La supervision permanente d'un adulte est nécessaire lors de l'utilisation des équipements/jouets TP par des enfants. Pour des raisons de sécurité, il est conseillé de s'assurer que les enfants utilisent les équipements/jouets correctement et ne portent pas de casque pour vélo, ni de vêtements lâches ou de bijoux, qui pourraient être retenus ou s'accrocher.
- 5. UTILISATION ET CONDITIONS MÉTÉOROLOGIQUES**
Une prudence accrue est recommandée lors de certaines conditions météorologiques. Les équipements/jouets de plein air deviennent glissants avec la pluie. Lorsqu'il gèle, il est recommandé de faire attention car les lèvres et la langue peuvent "coller" au métal. Par temps chaud et en cas d'exposition au soleil, il convient de vérifier régulièrement si la température de l'équipement/jouet n'est pas trop élevée, spécialement au niveau des éléments métalliques et des toboggans. En cas de doute, il est conseillé d'interdire l'usage du matériel. Si de forts vents sont attendus ou prévus, veuillez vous assurer que les installations de jeux d'extérieur sont soit mises à l'abri, soit bien fixées au sol ou à tout autre objet qui ne peut être déplacé.
- 6. JEUX AQUATIQUES**
Les équipements/jouets aquatiques peuvent devenir extrêmement glissants, ainsi une supervision attentive et une prudence accrue sont recommandées lors d'usage d'équipements de plein air utilisant de l'eau tels que des piscines gonflables, des toboggans aquatiques, etc.
- 7. ENTRETIEN**
Il est essentiel qu'un adulte se charge de contrôler chaque équipement/jouet à intervalles réguliers. L'ensemble de l'équipement/jouet, et en particulier toutes les pièces d'assemblage et les systèmes d'attache, doit être vérifié au moins une fois par mois. Si des pièces présentent des signes d'usure, il convient de remplacer la ou les pièces en question. Dans ce cas, l'équipement/jouet ne devra pas être utilisé tant que la ou les pièces de rechange n'auront pas été montées. Les Produits tubulaires galvanisés nécessiteront éventuellement un entretien occasionnel. Si de la rouille apparaît sur la structure, il convient de l'enlever avec une brosse métallique ou du papier de verre à gros grains, pour ensuite appliquer sur la surface à traiter une peinture non toxique.
- 8. RISQUES D'INCENDIE ET NON-USAGE**
Ne jamais placer ou utiliser les équipements/jouets TP à proximité de flammes nues. Si vous devez vous débarrasser d'un équipement/jouet, démontez-le en veillant à enlever toutes les vis. Si ce matériel doit être momentanément entreposé, assurez-vous de le maintenir hors de portée des enfants. Les présentes instructions ont été rédigées pour la sécurité de votre enfant et nous vous demandons de bien vouloir suivre nos conseils.

I

ISTRUZIONI DI MONTAGGIO, MANUTENZIONE E UTILIZZO DEI GIOCHI TP**Leggere attentamente tutte le seguenti informazioni e conservarle per riferimento futuro.**

- 1. INFORMAZIONI DI MONTAGGIO E SICUREZZA**
I giochi TP devono essere montati da un adulto. Devono essere eretti seguendo esattamente le istruzioni di montaggio fornite. La procedura di montaggio viene facilitata se si fa ricorso all'assistenza di un'altra persona. Per garantire la corretta messa in tensione e facilitare l'assemblaggio, è importante montare questo prodotto serrandolo inizialmente solo a mano. Serrare solo alla fine completamente e controllare tutti i dispositivi di fissaggio. Assicurarsi che tutti i dispositivi di fissaggio siano serrati bene prima dell'uso. Questa confezione può contenere pezzi piccoli e il suo contenuto, non è adatto per i bambini al di sotto di 3 anni di età. Si raccomanda di mettere i pezzi più piccoli in un vassoio o in un recipiente simile per evitare frustrazione e disappunto, o di perderli. Prestare particolare attenzione durante il montaggio del gioco, dato che il processo di fabbricazione può lasciare talvolta spigoli taglienti e pezzetti di metallo sciolti di scarto. Se dovessero per caso mancare dei pezzi, non usare il gioco prima di avere montato i pezzi mancanti di ricambio. Per la linea del Servizio Clienti TP: Email directsales@tp toys.com
- 2. POSIZIONAMENTO DEI GIOCHI**
Non posizionare in alcun caso i giochi su superfici dure come quelle di calcestruzzo o di asfalto, a meno che il terreno sotto il gioco e lo spazio libero circostante raccomandato siano coperti con una superficie di sicurezza. Superfici di tipo adatto sono quelle erbose, sabbiose o per giochi intese per tale uso. I giochi TP devono essere posizionati su terreno in pari. Non camminare e non arrampicarsi sulle tende "TP".
- 3. UTILIZZO**
A meno che sia indicato altrimenti, i giochi TP sono progettati e costruiti per essere usati dai bambini di età fra 36 mesi e 8 anni, e non devono essere usati da altre persone. Un cattivo uso può provocare lesioni personali. Non camminare e non arrampicarsi sulle tende "TP".
- 4. SORVEGLIANZA**
I bambini devono essere sempre sorvegliati quando si divertono con i giochi TP, ed è necessario insegnare loro a non usare i giochi in maniera incorretta o pericolosa. Si raccomanda che i bambini non indossino indumenti sciolti o articoli di gioielleria che durante il gioco possono restare impigliati o agganciatoli. I bambini non devono indossare caschi per bicicletta quando si divertono con i giochi TP.
- 5. CONDIZIONI ATMOSFERICHE**
Prestare particolare attenzione al cambiare delle condizioni atmosferiche, dato che con la stagione bagnata le superfici possono diventare scivolose. Quando la temperatura è sotto zero le labbra e la lingua possono aderire alle parti di metallo, mentre nella stagione calda e soletta i vari elementi dei giochi possono diventare molto caldi; bisogna controllarne perciò con regolarità la temperatura, specialmente quella dei componenti metallici e degli scivoli. Non usare i giochi se sussiste alcun dubbio sulla loro sicurezza. Se si ci si aspettano o si prevedono venti forti, assicurarsi che i giochi installati all'aperto siano trasferiti in una posizione protetta, oppure assicurarsi che siano trasferiti in una posizione protetta, oppure assicurarsi che siano fissati saldamente al terreno o ad altri oggetti che non possono muoversi.
- 6. GIOCHI CON L'ACQUA**
Nei giochi con l'acqua, molte superfici possono diventare scivolose. Quando ad altre forme di giochi all'aperto si abbina l'acqua (come ad esempio nelle piscine basse per bambini piccoli, negli scivoli ad acqua, ecc.) bisogna essere particolarmente attenti ed esercitare stretta sorveglianza.
- 7. MANUTENZIONE**
Come per tutti i giochi, è d'importanza vitale che le attrezzature siano controllate regolarmente e spesso da un adulto. Controllare tutto il gioco almeno una volta al mese, prestando particolare attenzione alle connessioni e ai dispositivi di fissaggio. Se qualsiasi parte presenta segni di deterioramento o di usura, può essere necessario cambiarla. Mancando di farlo si può provocare il cattivo funzionamento del prodotto e produrre lesioni personali. Non lasciare che i bambini usino questo gioco prima che sia stato installato nel modo dovuto e controllato attentamente. I prodotti tubolari in acciaio zincato possono richiedere manutenzione occasionale. Se appare ruggine sulla loro superficie, rimuoverla usando una spazzola metallica o tela smeriglio grossa, e trattare poi l'area interessata con una vernice non tossica.
- 8. RISCHI E PROCEDURE PER L'ELIMINAZIONE**
Non permettere mai che i giochi TP siano posizionati od usati vicini al fuoco. Quando diventa necessario distarsi dei giochi, rimuovere tutti i bulloni e smontarli, tenendoli fuori della portata dei bambini fino a quando possono essere eliminati nel modo dovuto. Queste istruzioni sono preparate nell'interesse della sicurezza dei bambini e si raccomanda di seguire tutti i consigli ivi contenuti.

E

INSTRUCCIONES DE MONTAJE, MANTENIMIENTO Y USO DE LOS JUGUETES TP**Lea detenidamente toda la información adjunta y consérvela para futuras consultas.**

- 1. INFORMACIÓN SOBRE MONTAJE Y SEGURIDAD**
Los juguetes TP deben ser montados por un adulto. Deben armarse siguiendo fielmente las instrucciones de montaje, y será más fácil hacerlo con la ayuda de otro adulto. A fin de asegurar las tensiones correctas y para que el armado sea fácil, es importante armar el producto solamente a mano para comenzar. Sólo cuando esté terminado, deberían ajustarse los fijadores complementarial y ser verificados. Asegúrese por favor de que todos los fijadores estén firmes o apretados antes de usar el juego. Este paquete puede incluir piezas pequeñas, por lo que no es apropiado para niños menores de 3 años. Recomendamos que coloque las piezas pequeñas en una bandeja o recipiente similar, para evitar la frustración de no saber dónde las ha puesto. Tenga cuidado durante el montaje, ya que tras el proceso de fabricación pueden aparecer a veces bordes afilados y pequeños restos metálicos. Si falta alguna pieza, el juguete no debe usarse hasta que se hayan procurado las piezas de repuesto. El teléfono de atención al cliente de TP es: Email directsales@tp toys.com
- 2. EMPLAZAMIENTO**
Nuestros juguetes no deben, en ningún caso, colocarse sobre una superficie dura, por ejemplo de cemento o asfalto, a menos que el suelo bajo el juguete y la zona libre recomendada estén cubiertas con una superficie segura. Algunos ejemplos de superficies aptas serían de hierba, arena o superficies de juego preparadas para este propósito. Los juguetes TP deben emplazarse en suelo llano.
- 3. USO**
Los juguetes TP están diseñados y fabricados para niños de entre 36 meses y 8 años, a menos que aparezca otra indicación, y no deben ser usados por personas de otras edades. El uso inapropiado de estos productos puede causar daños personales. No debe caminar por encima de las carpas 'TP' ni treparse por ellas.
- 4. SUPERVISIÓN**
Mientras jueguen con los juguetes TP, los niños deben ser supervisados, y se les debe advertir que no deben usarlos de un modo inadecuado o peligroso. Recomendamos que no lleven prendas muy amplias o adornos que se puedan enganchar mientras juegan. No deben llevar cascos de ciclista cuando juegan con juguetes TP.
- 5. CONDICIONES METEOROLÓGICAS**
Durante los cambios meteorológicos se deben tomar mayores precauciones. En concreto, los juguetes para exteriores pueden resultar resbalosos en la lluvia, y los labios y la lengua pueden pegarse al metal a temperaturas inferiores a los 0°C. En días calurosos y soleados, puede que algunas piezas se recalienten, por lo que la temperatura del juguete debe comprobarse con frecuencia mientras se usa, especialmente las piezas metálicas y los toboganes. En caso de albergar alguna duda sobre la seguridad del uso del juguete, deben abstenerse de usarlo. Si se esperan o han sido pronosticados vientos fuertes, por favor verifique que los juegos de exteriores sean trasladados a un lugar protegido o que sean fijados en forma segura al suelo o a otro objeto fijo.
- 6. JUEGOS DE AGUA**
Muchas superficies pueden volverse resbalosas cuando se juega en el agua. Se debe prestar un mayor cuidado y una supervisión más estricta cuando se combina el agua (por ejemplo, una piscina inflable, toboganes acuáticos, etc.) con otras formas de jugar al aire libre.
- 7. MANTENIMIENTO**
En el caso de todos los juguetes, es de suma importancia que el equipo sea revisado con bastante regularidad por un adulto. El juguete completo debería ser revisado al menos una vez al mes, prestando especial atención a las conexiones y las sujeciones. Si alguna pieza presenta señales de desgaste o rotura, puede que necesite ser reemplazada. De no hacerlo, puede que el producto deje de funcionar correctamente y que cause un daño. No se debe permitir que los niños usen el juguete hasta que esté instalado y haya sido revisado. Los productos tubulares galvanizados pueden necesitar trabajos de mantenimiento ocasionales. Si aparece óxido en la superficie, debe quitarse con un cepillo de alambre o con papel de lija grueso, y se debe tratar la zona con una pintura no tóxica.
- 8. PELIGRO DE INCENDIO Y COMO TIRAR EL JUGUETE**
Nunca permita colocar o usar un juguete TP cerca del fuego. Llegado el momento de tirar el equipo, retire todos los tornillos y desmóntelo. Guárdelo fuera del alcance de los niños hasta el momento de deshacerse del mismo.
Estas instrucciones se facilitan para la seguridad del niño. Le rogamos que siga nuestros consejos.

D

ANLEITUNG ZUR MONTAGE, WARTUNG UND GEBRAUCH VON TP SPIELGERÄT**Bitte lesen Sie diese Anleitung vor der Montage und der ersten Benutzung sorgfältig durch.****Bitte bewahren Sie diese Anleitung zur Information, bzw. für Wartungsarbeiten und Ersatzteilbeschaffung auf.**

- 1. MONTAGE**
Dieses Spielgerät muß durch einem Erwachsene aufgebaut werden. Befolgen Sie dabei genau die Bauanleitung. Das erzeuignis soll zuerst nur fingerfest verschraubt werden, um sicher zu stellen, dass es sich nicht verzieht und um den zusammenbau zu erleichtern. Erst nachdem alle teile zusammen gebaut sind, sollten sie fest angezogen und überprüft werden. Stellen sie sicher, dass alle befestigungen vor gebrauch fest angezogen sind. Dieser Artikel enthält Kleinteile und ist daher Nicht für Kinder unter 36 Monaten geeignet. Bitte achten Sie auf scharfkantige Bohrungen und Späne, die unter Umständen in der Herstellung dieses Spielgerätes anfallen können. Sollten Einzelteile fehlen, so darf das Spielgerät nicht benutzt werden. Bitte sorgen Sie dafür, daß die notwendigen Ersatzteile montiert werden. Sie können Einzelteile beim TP Kundenservice: Email directsales@tp toys.com
- 2. STANDORT**
Unsere Spielgeräte dürfen unter keinen Umständen auf hartem Untergrund (Asphalt oder Beton) aufgestellt werden und sollte ebenerdig sein. Der Standort muß so gewählt werden, daß ausreichende Sicherheitsabstände gewährleistet sind.
- 3. VERWENDUNGSBEREICH**
Verwendungsbereich - Dieses Spielgeräte dürfen nur bestimmungsgemäß verwendet werden, d.h. als Kinderspielgerät im ausschließlich privaten Garten für eine dem Gerät angemessene Anzahl von Kindern von 36 Monaten bis 8 Jahre alt. Jegliche andere Verwendung ist unzulässig und möglicherweise gefährlich. TP Activity Toys übernimmt keine Haftung für Schäden, die aus nicht zweckgemäßen Gebrauch entstehen.
- 4. BEAUFSICHTIGUNG**
Kinder sollten nur unter Beaufsichtigung von Erwachsenen mit TP Spielgeräten spielen und sollten über den zweckmäßigen Gebrauch unterrichtet werden. Wir empfehlen, daß Kinder keine lose Kleidung oder Schmuck beim Spielen tragen, außerdem dürfen keine Fahrradhelme getragen werden.
- 5. WETTEREINFLÜSSE**
Achten Sie darauf, daß unser Spielzeug, vor allem die Plastik- und Metallteile, ganzjährig allen Wetterbedingungen ausgesetzt ist. Stellen Sie sicher, daß unter widrigen Bedingungen nicht mit dem Spielgerät gespielt wird. Wenn starker wind erwartet oder vorhergesagt wird, stellen sie bitte sicher, dass die Spielzeuge im freien entweder unter schutz gestellt werden oder am grund oder einem festen punkt fest gezurr werden.
- 6. SPIELEN MIT WASSER**
Beim Spielen in Verbindung mit Wasser (Planschbecken, Wasserutsche, usw.) sollte besondere Vorsicht geboten sein, da das Spielgerät sehr rutschig werden kann.
- 7. WARTUNG**
Es ist für Spielzeug im allgemeinen notwendig, daß Kleinteile und Verbindungen von einem Erwachsenen in regelmäßigen Abständen auf ihre Funktionstüchtigkeit überprüft werden. Führen Sie in monatlichen Abständen, dem Spielbetrieb angemessen, regelmäßige Kontrollen aller Schraub- und anderen Verbindungen durch. Ein nicht angemessenes Überprüfen des Zustandes, kann die Lebensdauer des Spielgerätes verringern und die Sicherheit Ihrer Kinder gefährden. Verschlossene Teile sollten frühzeitig ersetzt werden. Zink galvanisierte Teile können unter Umständen Roststellen aufweisen. Sie sollten diese mit einer Drahtbürste behandeln und mit ungiftiger Schutzfarbe überstreichen.
- 8. ENTSORGUNG**
Bevor Sie Ihr Gerät entsorgen, entfernen Sie alle Schraubverbindungen und lagern es so, daß Kinder keinen Zugriff auf einzelne Teile haben. Es ist ratsam, die Kleinteile während der Montage an einem sicheren Platz aufzubewahren, damit Sie keine Schrauben oder Muttern verlieren. Dieses Spielgerät muß von einem Erwachsenen aufgebaut werden.

P

INSTRUÇÕES PARA MONTAGEM, MANUTENÇÃO E USO DE BRINQUEDOS**Leia com atenção as informações que se seguem e guarde-as para futuras consultas.**

- 1. INFORMAÇÃO A RELATIVA MONTAGEM E SEGURANÇA**
Os brinquedos devem ser montados por adultos e seguindo sempre de forma exacta as instruções de montagem. A montagem poderá ser facilitada pela presença de um ajudante. Para garantir que são exercidas as tensões correctas e para facilitar o processo de montagem, é importante que o produto seja primeiro apertado só à mão. Só quando a montagem estiver concluída, é que se deve apertar totalmente e fazer uma verificação geral. Antes da utilização, certifique-se de que todos os fechos estão bem apertados. Esta embalagem poderá conter peças de pequenas dimensões, não sendo adequada para crianças de idade inferior a 36 meses. Recomendamos que coloque as peças de pequenas dimensões num tabuleiro ou superfície semelhante de modo a que não as perca. Tenha cuidado durante a montagem, já que o processo de fabrico pode por vezes resultar em arestas afiadas e em pequenos pedaços de metal soltos. Caso haja peças em falta, o brinquedo não deve ser usado até que estas sejam obtidas e montadas. A linha de Apoio ao Cliente é Email directsales@tp toys.com
- 2. COLOCAÇÃO**
Em circunstância alguma devem os nossos brinquedos ser colocados numa superfície rígida, como cimento ou alcatrão, a não ser que a superfície sob o brinquedo e a superfície adicional envolvente recomendada estejam cobertas por uma superfície de segurança. A relva, areia ou superfícies desportivas são exemplos de superfícies adequadas para esta utilização. Os brinquedos devem ser colocados ao nível do chão.
- 3. UTILIZAÇÃO**
Os brinquedos foram concebidos apenas para uso doméstico familiar no exterior e só por crianças com idades entre os 36 meses e os 8 anos, e não devem ser usados por pessoas de outras idades. O não seguimento destas instruções de uso poderá resultar em ferimentos.
- 4. SUPERVISÃO**
As crianças devem ser sempre vigiadas por um adulto enquanto estiverem a brincar nos brinquedos e devem ser ensinadas a não usar o brinquedo de forma inadequada ou perigosa. Recomenda-se que as crianças não usem roupas muito largas, nem peças de bijuteria que possam ficar presas ou emaranhar-se durante a brincadeira. As crianças não devem usar capacetes de bicicleta enquanto brincam nos brinquedos.
- 5. CONDIÇÕES METEOROLÓGICAS**
Devem ser tomadas precauções no caso de as condições meteorológicas se alterarem. Em especial, os brinquedos de exterior podem tornar-se escorregadios em condições chuvosas e, a temperaturas negativas, os lábios podem colar-se ao metal. Em condições meteorológicas mais temperadas e soalheiras, as peças podem aquecer, pelo que a temperatura deve ser verificada com regularidade durante a brincadeira, especialmente no que diz respeito a peças metálicas e corrediças. Caso haja alguma dúvida quanto à segurança de um brinquedo, o mesmo não deverá ser usado. Caso haja previsão de ventos fortes, certifique-se de que os brinquedos de exterior são movidos para uma área resguardada ou que estão bem presos ao chão ou a outros objectos imóveis.
- 6. BRINCAR COM ÁGUA**
Muitas superfícies podem tornar-se escorregadias quando as brincadeiras incluem água. É necessário vigiar e tomar cuidados adicionais ao combinar água (por exemplo, em piscinas insufláveis, escorregões de água, etc.) com outras formas de brincadeiras no exterior.
- 7. MANUTENÇÃO.**
Com todos os brinquedos é essencial que o equipamento seja verificado por um adulto de forma regular e frequente. O brinquedo completo deve ser verificado pelo menos uma vez por mês, dando particular atenção às ligações e fechos. Qualquer peça que exiba sinais de desgaste e muito uso deve ser substituída. O não cumprimento desta regra poderá causar um mau funcionamento do produto e possíveis ferimentos. As crianças não devem ser autorizadas a usar o brinquedo até que este esteja totalmente montado e verificado. Caso apareça ferrugem na superfície, esta deve ser removida com uma escova metálica ou com papel de lixa áspero e a área deve ser tratada com uma tinta não tóxica.
- 8. RISCOS DE INCÊNDIO E ELIMINAÇÃO**
Nunca permita que os brinquedos sejam utilizados ou colocados perto de fogo. Quando chegar a altura de eliminar o equipamento, remova todos os parafusos e desmonte-o. Guarde fora do alcance das crianças até que se possa destazer do brinquedo de forma adequada.

Instruction Guide

Read Instructions Before Starting

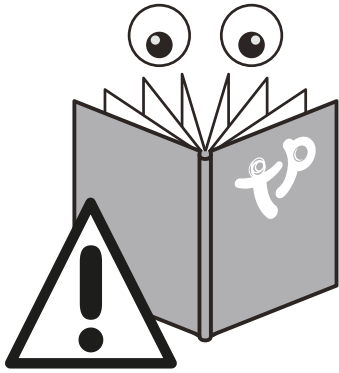

Hidden Lines

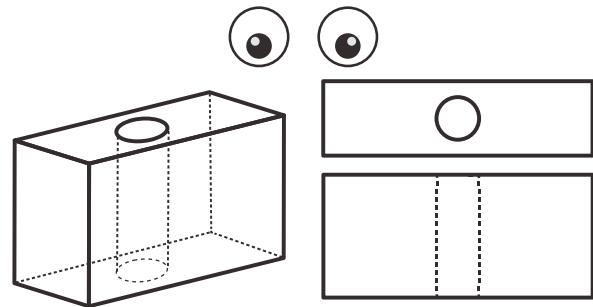

Sort Fixings

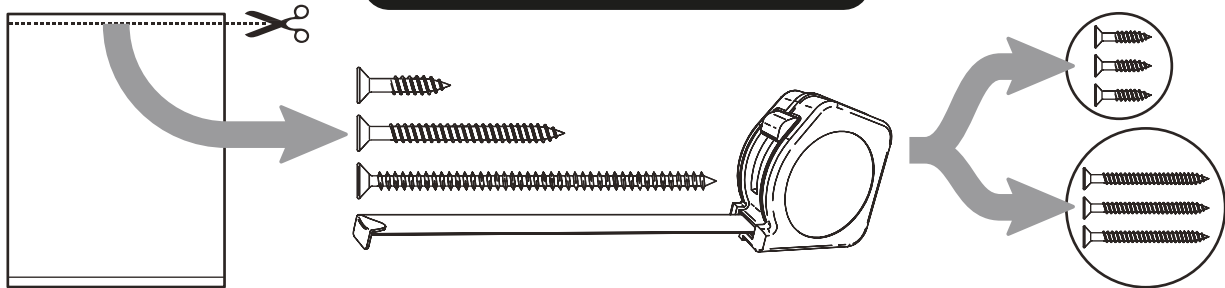

Sort Parts

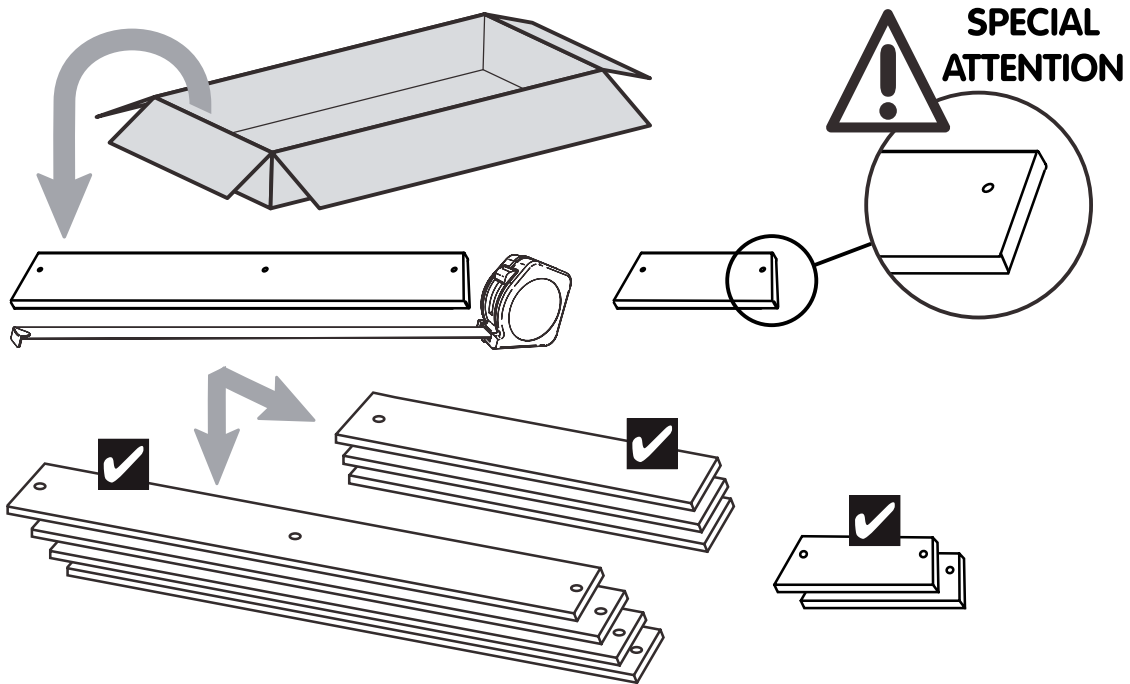

Need Help?

Visit: www.tptoys.com

TP Customer Services (English Speaking)

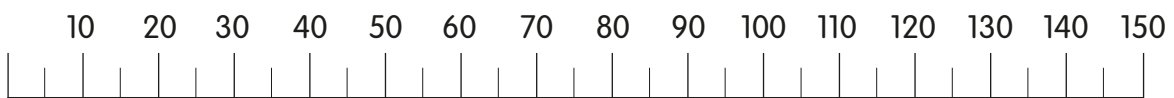

Contents - Please check

Siete Pregati di Controllare il Contenuto

Verifique El Contenido

Conteúdos - Por favor verifique

Inhalt - Bitte Überprüfen

Contenu - Veuillez Vérifier

Tools - You will need:

Vous aurez besoin de:

Sie benötigen:

Avrete bisogno:

Precisarà:

Vai precisar:



Power Screwdriver



Tape Measure



Screwdriver



Hand Saw



Pozi #2



Pozi #3

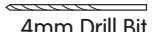

4mm Drill Bit



10mm Spanner



Spirit Level

TP351 - Box 1 of 2 - House parts

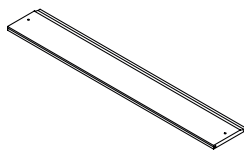

MW2515
772mm
x12

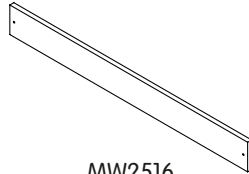

MW2516
1061mm
x11

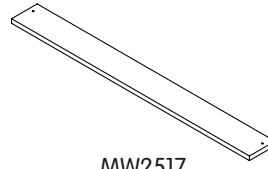

MW2517
1061mm
x4

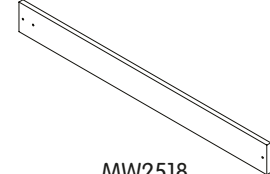

MW2518
1098mm
x2

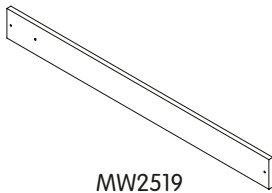

MW2519
1151mm
x2

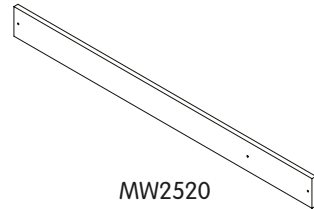

MW2520
1286mm
x3

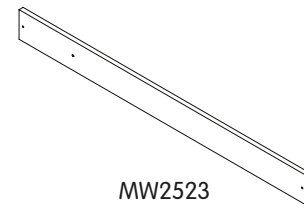

MW2523
1246mm
x2



PM1007
Flag
x1

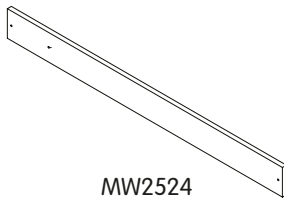

MW2524
1200mm
x3

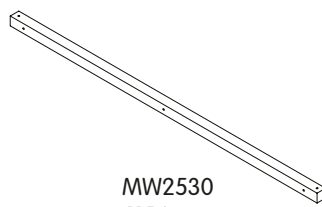

MW2530
1154mm
x1

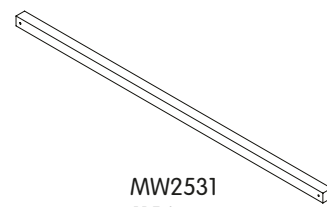

MW2531
1154mm
x2

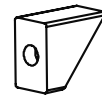

MW2510
Chimney Block
80mm
x1



PM2040
x3



MW2521
195mm
x2

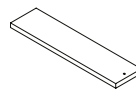

MW2522
564mm
x6



MW2525
232mm
x2



MW2526
285mm
x2

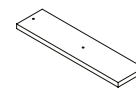

MW2527
380mm
x2

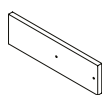

MW2528
334mm
x1

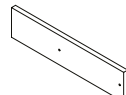

MW2529
420mm
x1



MW2533
81mm
x1

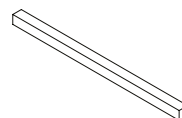

MW2534
628mm
x4

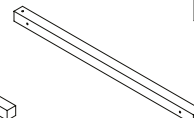

MW2535
672mm
x1

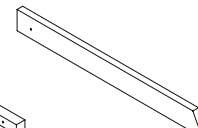

MW2536
693mm
x4



MW2550
1061mm
x1

SP7945 - Box 1 of 2 - House Fixings

FA4516
4.5 x 15mm x24



FA9761
5 x 100mm x8



FA4513
4.5 x 30mm x110



PM2038
x24

TP351 - Box 2 of 2 - Platform Parts

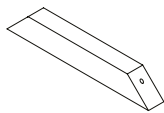

MW0169
294mm
x8

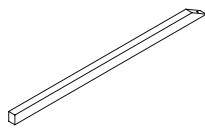

MW0172
997mm
x2

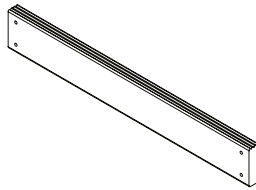

MW1501
414mm
x3

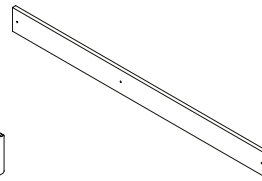

MW2540
1189mm
x11

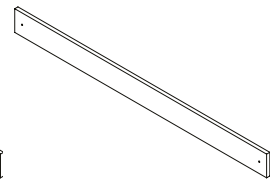

MW2541
1161mm
x2

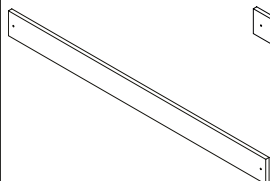

MW2542
1145mm
x2

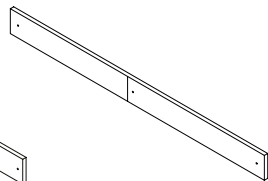

MW2543
1194mm
x1

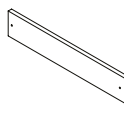

MW2544
583mm
x1

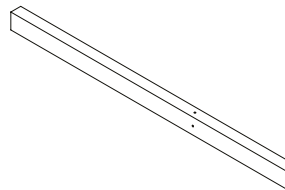

MW2545
1223mm
x2

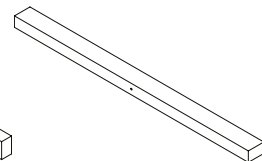

MW2546
1041mm
x3

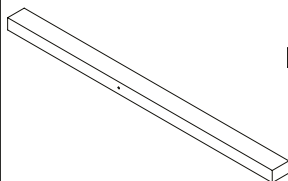

MW2547
1101mm
x2

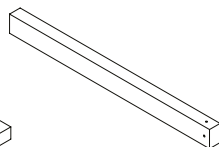

MW2548
832mm
x2

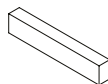

MW2549
376mm
x1

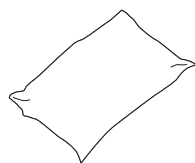

FB9985
Sandpit Liner
x1



PM2001
Ground Peg
x2

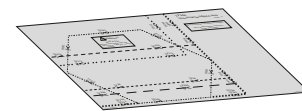

EL 9061
x1
TP346
Universal Sandpit Cover
x1

SP7942 - Box 2 of 2 - Platform Fixings

FA4517
4.5 x 40mm x46



FA9768
5 x 60mm x2

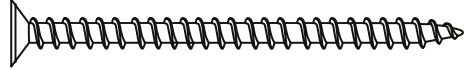

FA9705
4.5 x 50mm x31



FA4521
5 x 80mm x6



FA9761
5 x 100mm x4



FA9784
M6 x 150mm x7

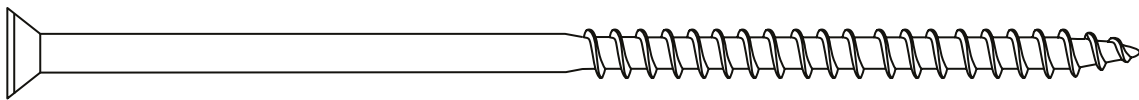

FA5164
M6 x 35mm
x1



FA5192
M6 Nylon
Insert
Dome Nut
x1



FA5095
M6 Washer
x1

Fixing guide

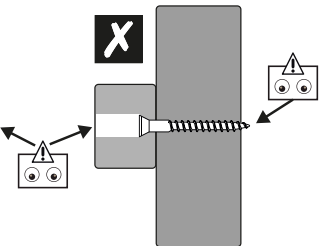
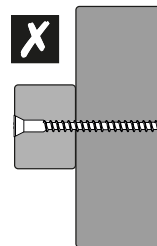
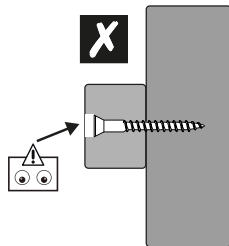
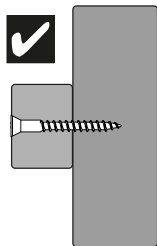

Pack 1 of 2: House

01

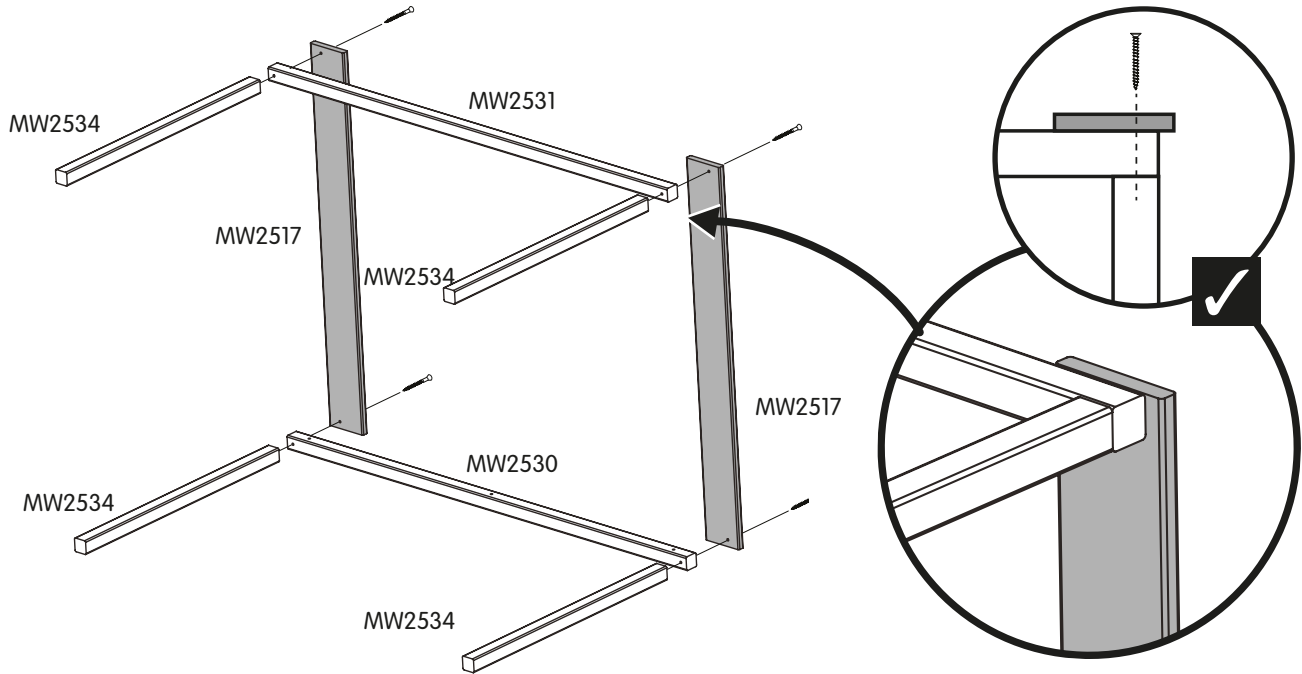
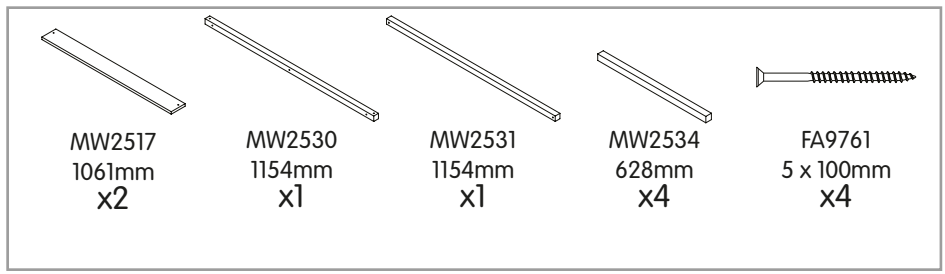

02

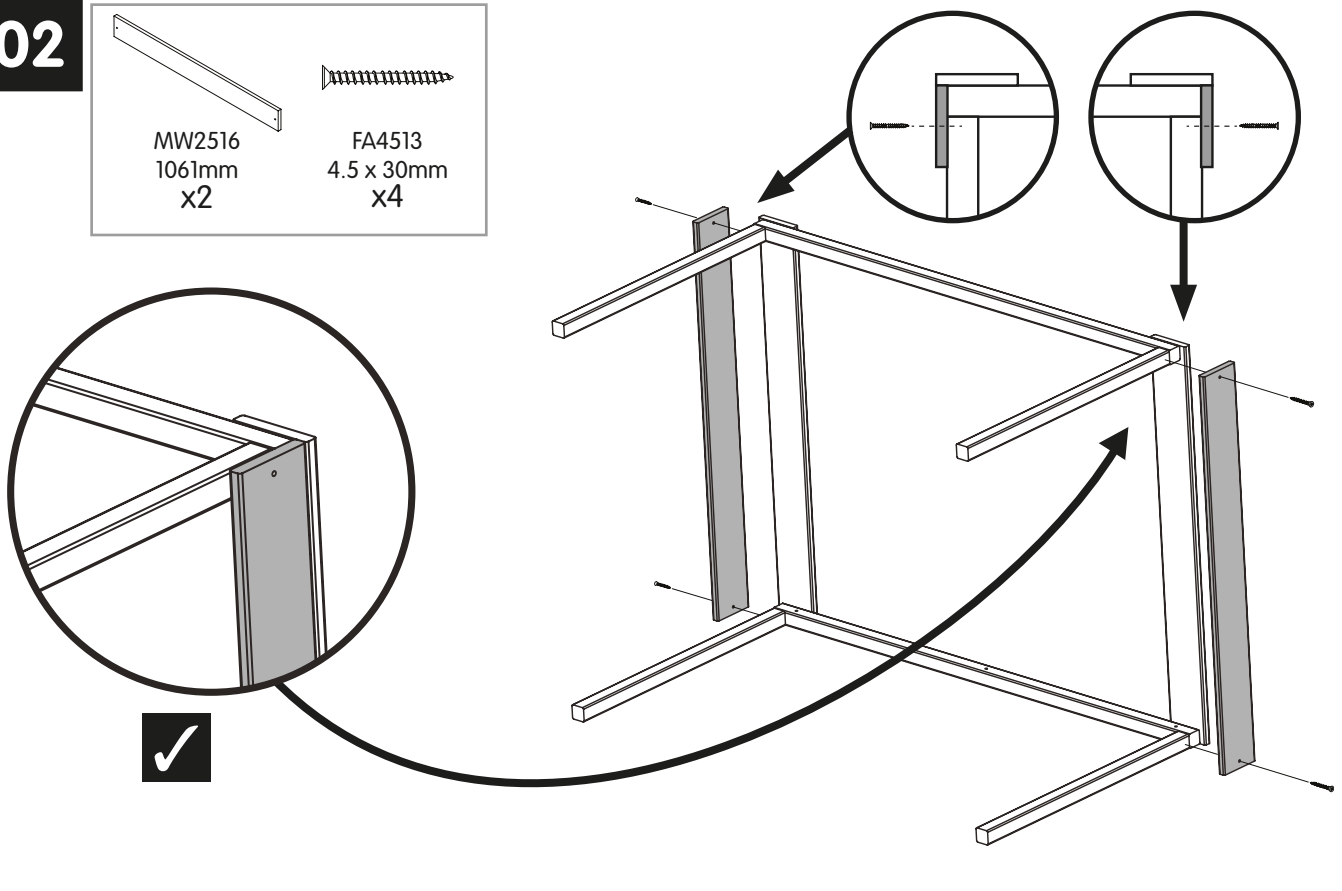
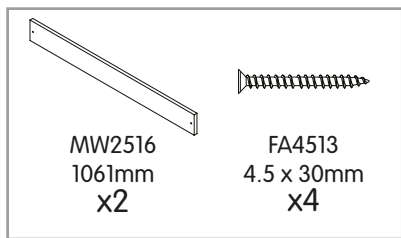

03

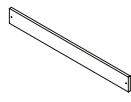

MW2516
1061mm
x1

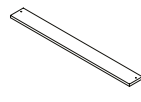

MW2517
1061mm
x2

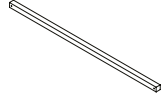

MW2531
1154mm
x1



MW2533
81mm
x1

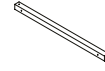

MW2535
672mm
x1



FA4513
4.5 x 30mm
x4

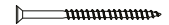

FA9761
5 x 100mm
x4



MW2550
1061mm
x1

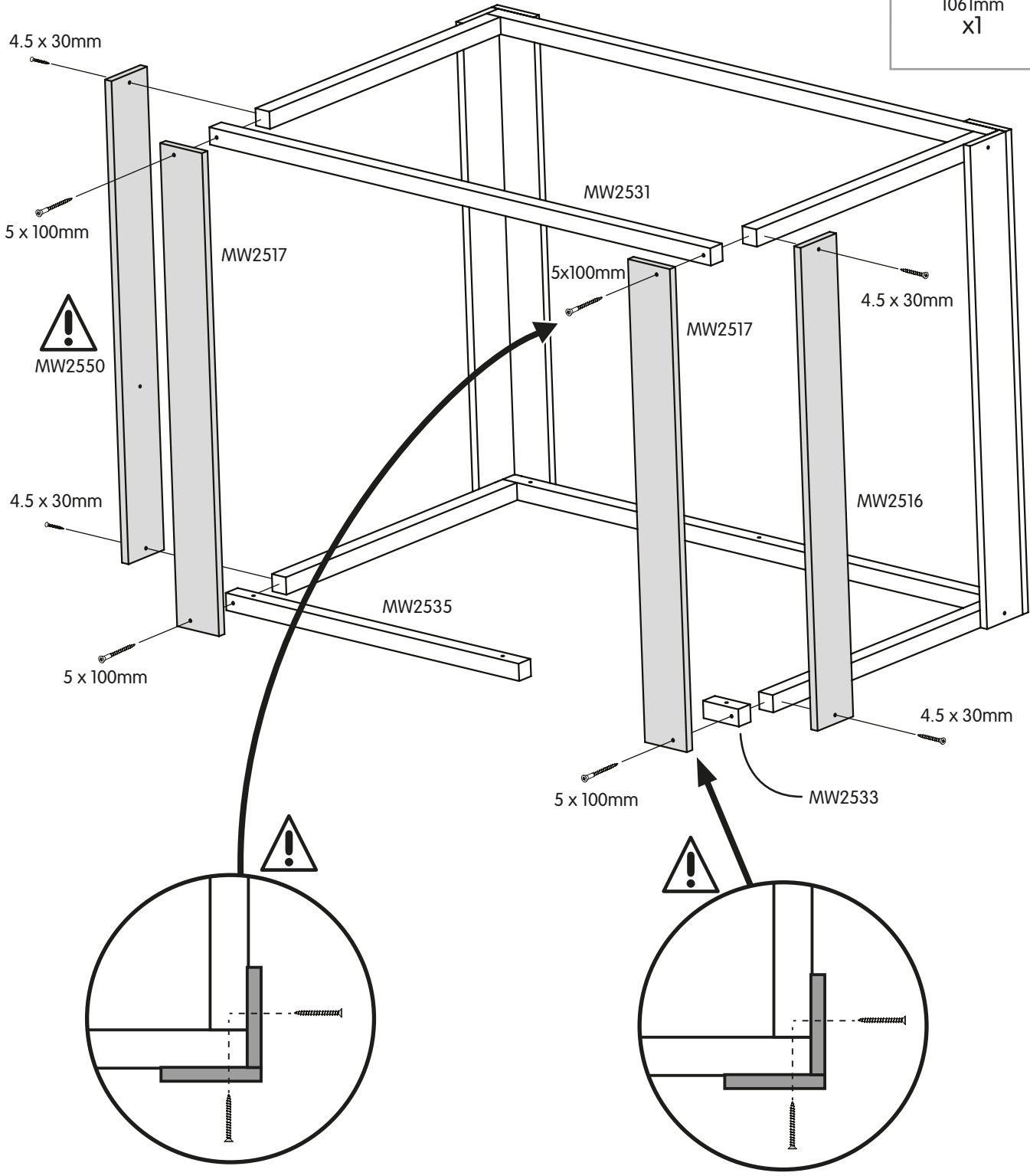

04

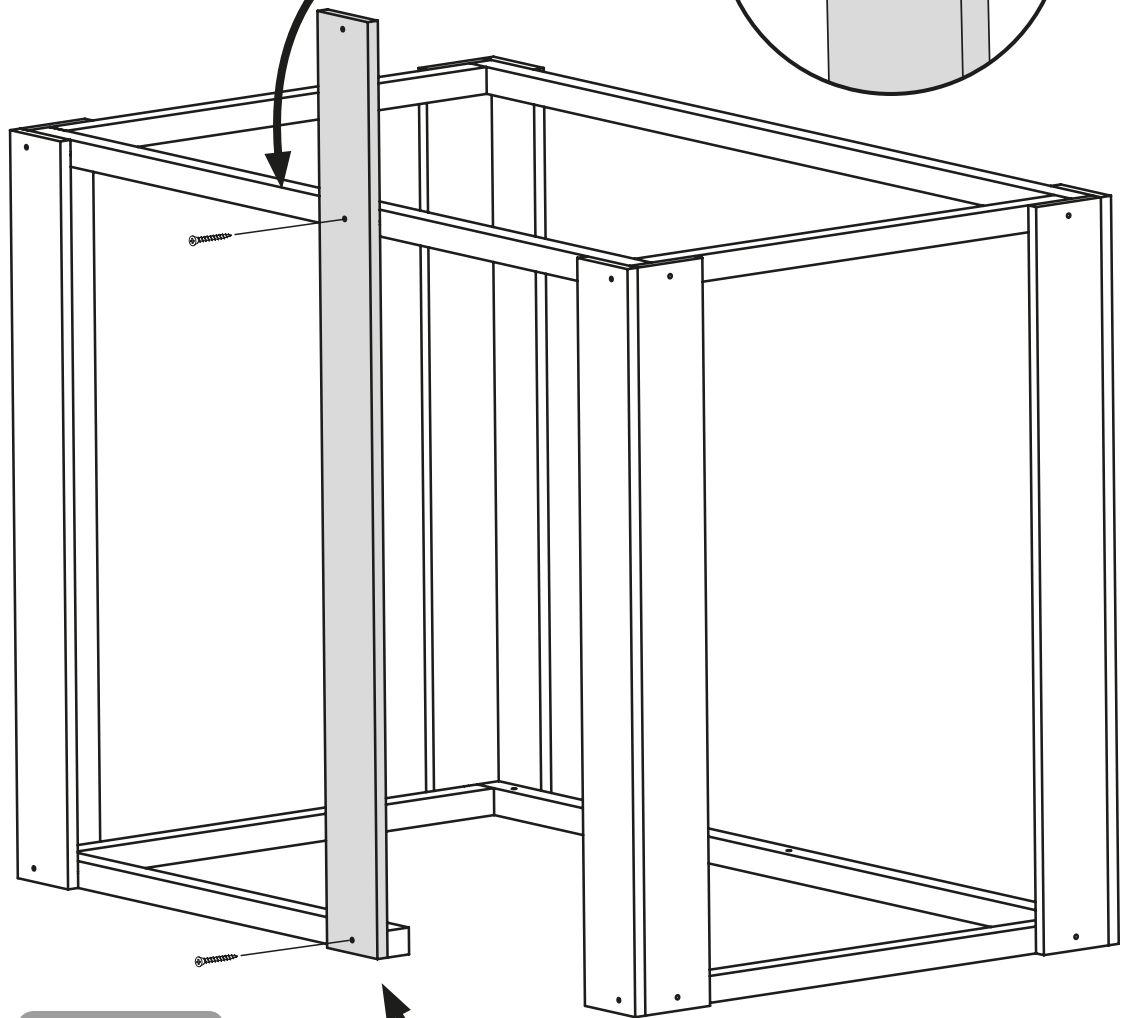
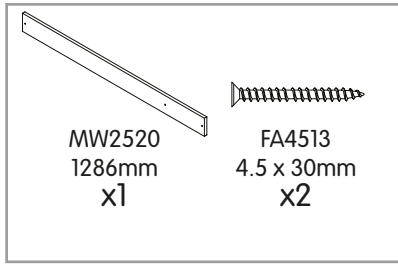

ASSEMBLY TIP

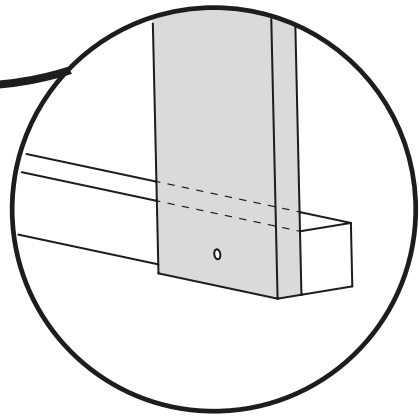
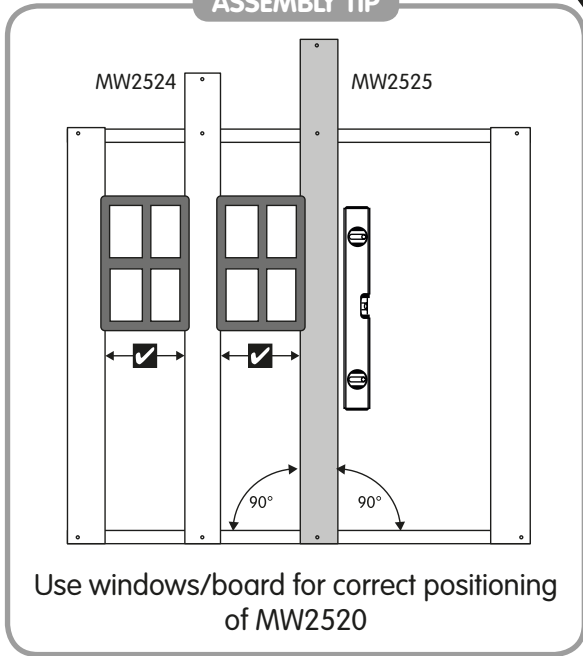

05

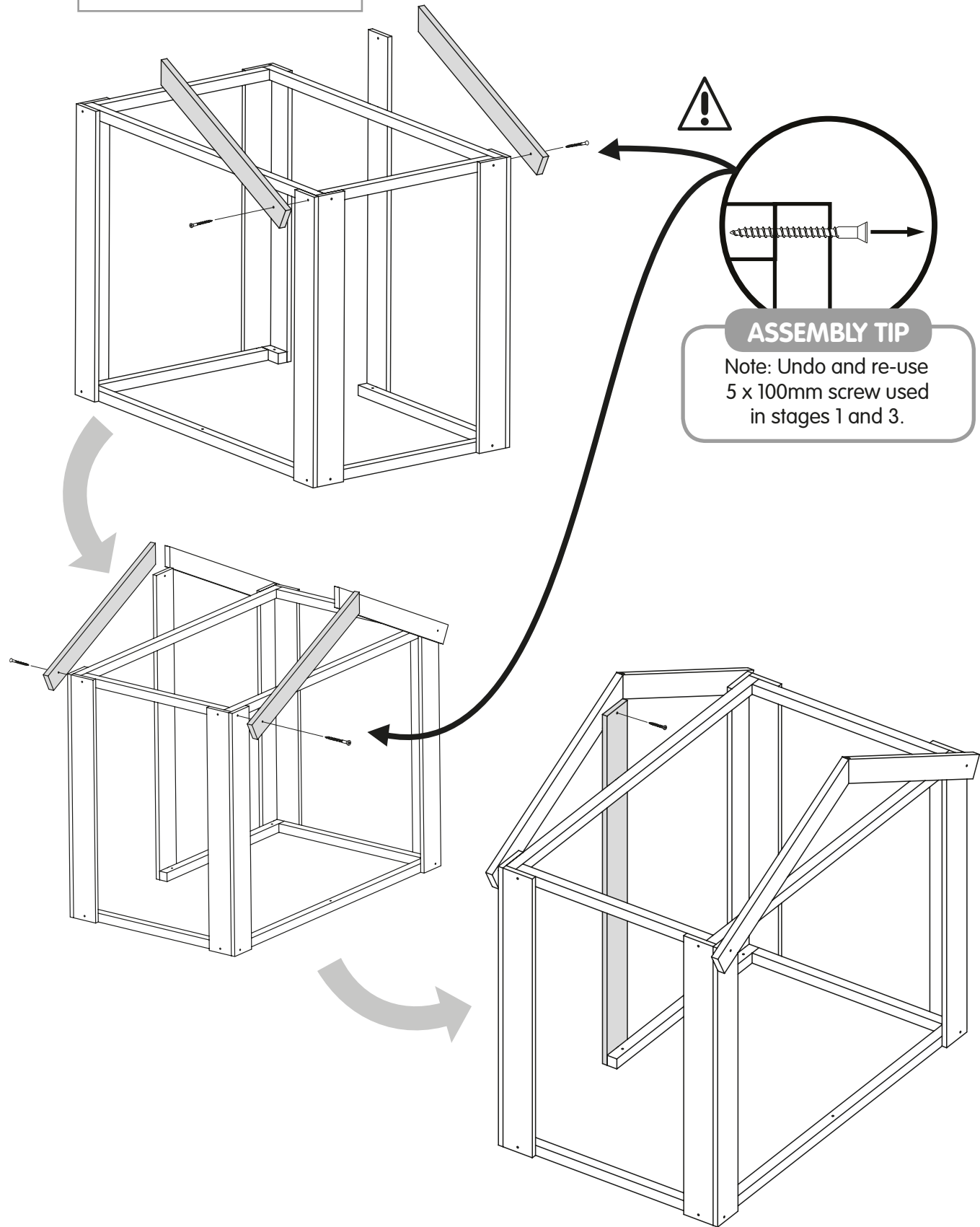
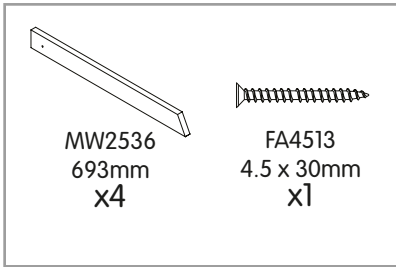

06

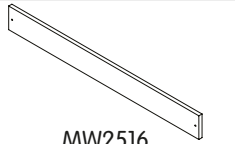

MW2516
1061mm
x5

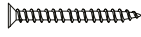

FA4513
4.5 x 30mm
x10

ASSEMBLY TIP

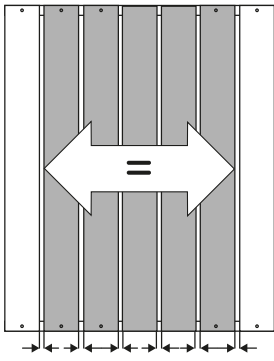

⚠ Space boards evenly.

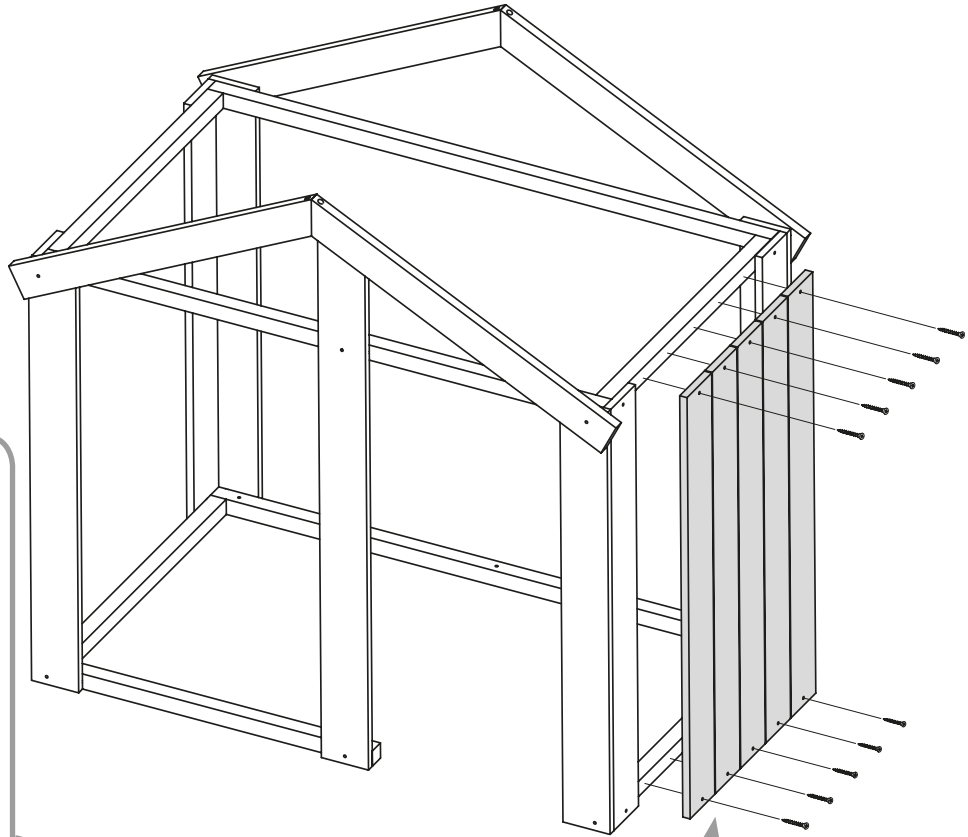

07



MW2516
1061mm
x3

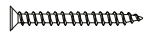

FA4513
4.5 x 30mm
x6

ASSEMBLY TIP

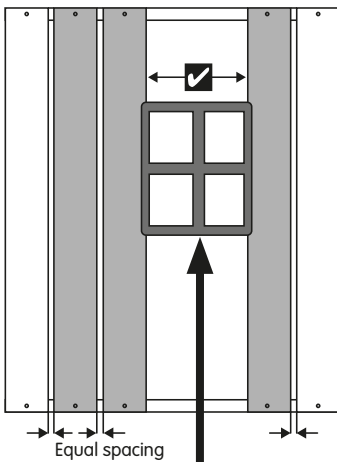

Use window to position boards correctly before fixing.

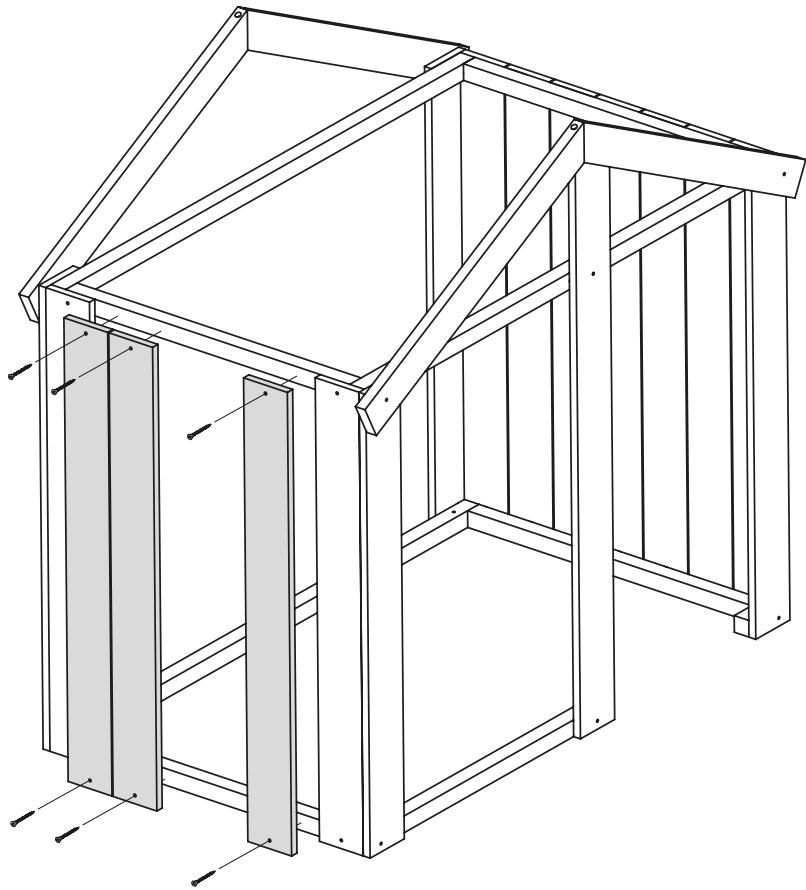

08

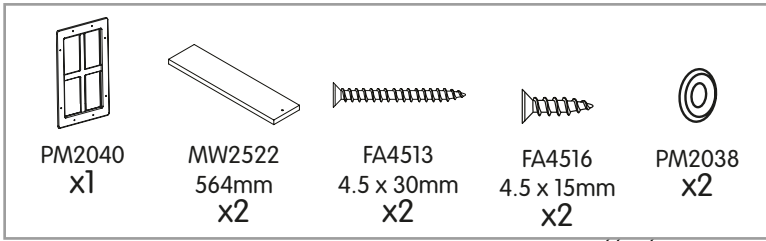

ASSEMBLY TIP

Use window for fixing position. Fix bottom boards first, then fix window with two screws.

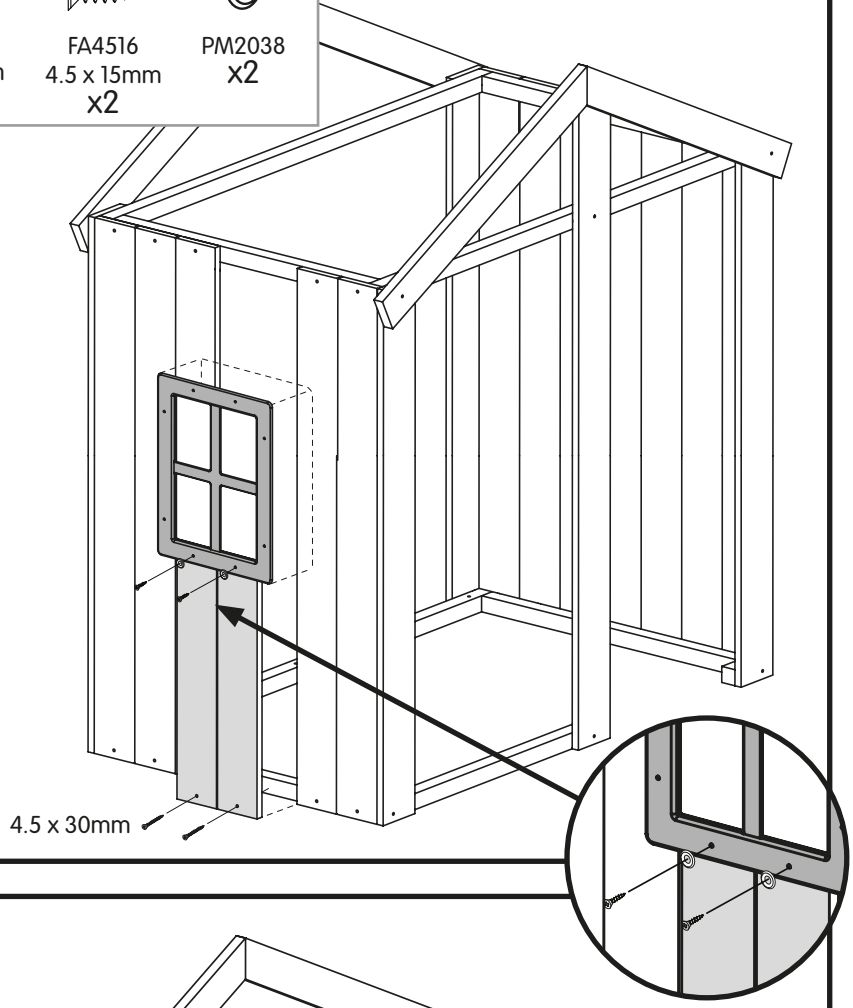

09

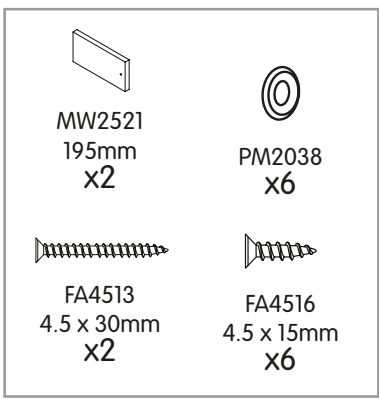

ASSEMBLY TIP

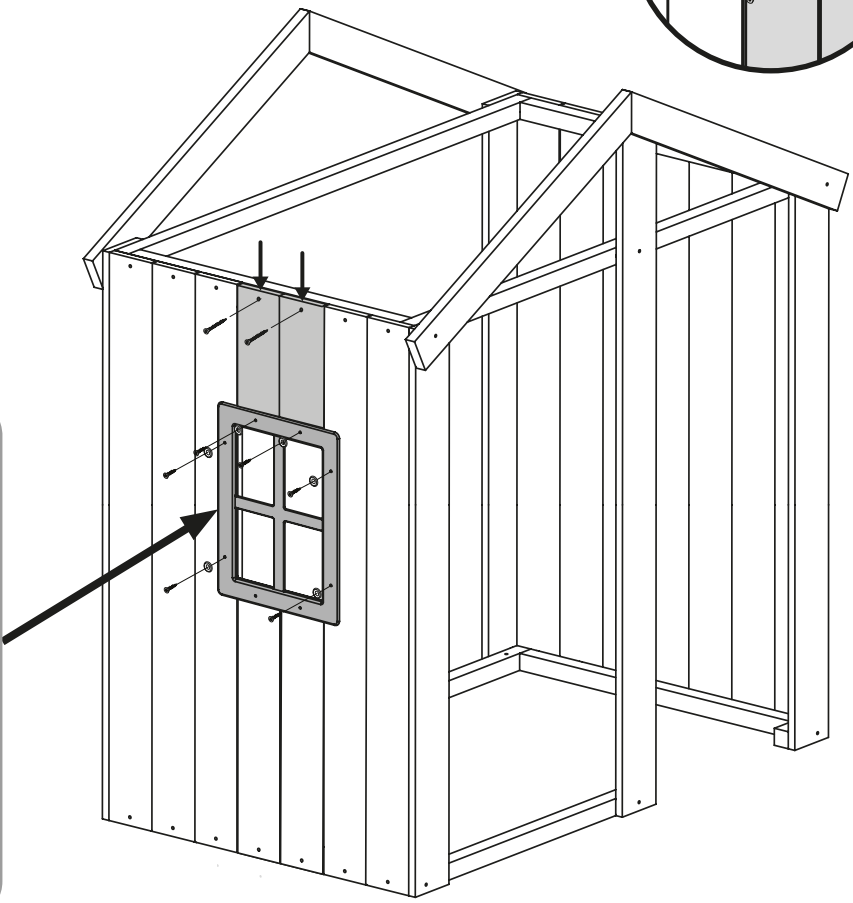

10

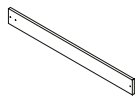

MW2518
1098mm
x2

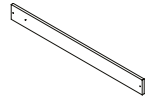

MW2519
1151mm
x2

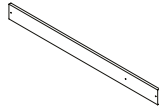

MW2520
1286mm
x2

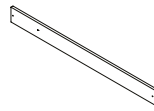

MW2523
1246mm
x2

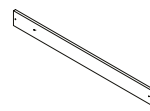

MW2524
1200mm
x2

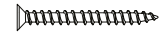

FA4513
4.5 x 30mm
x30

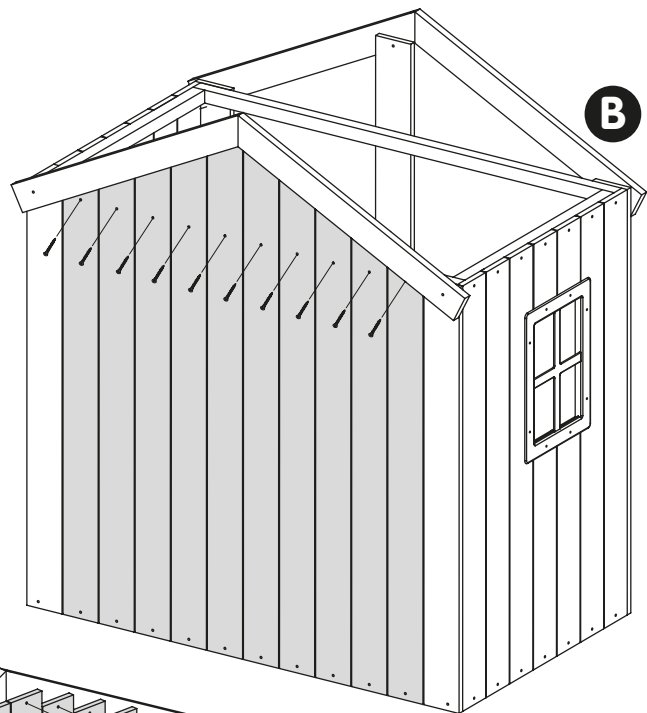
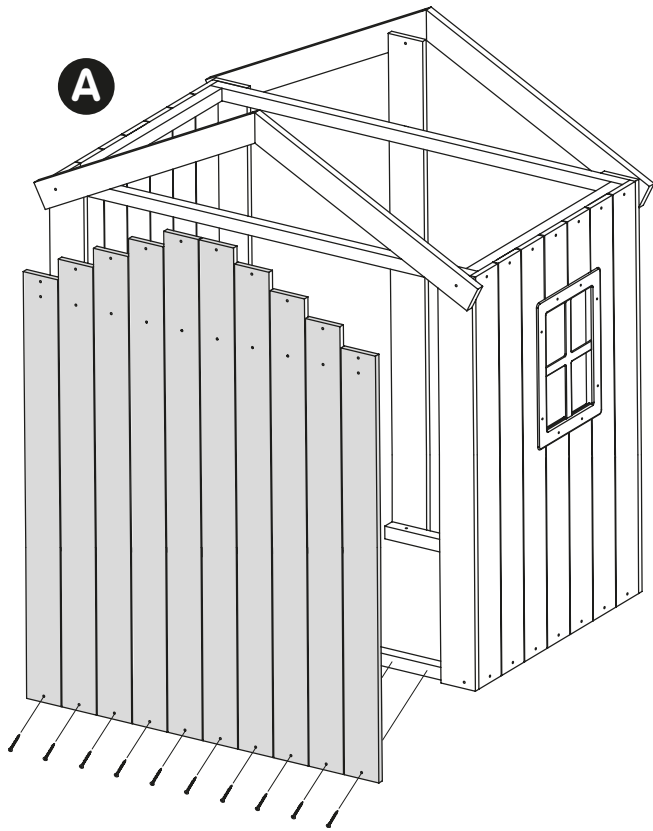

ASSEMBLY TIP

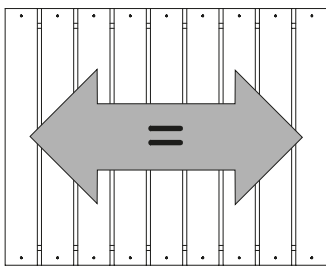

 **Space boards evenly.**

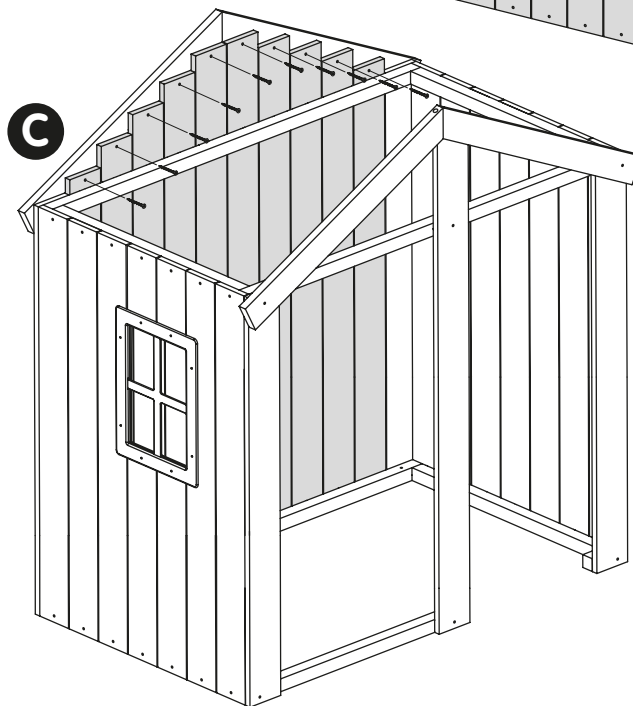

11

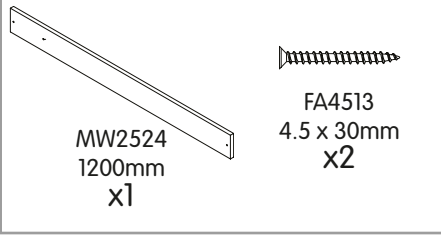

ASSEMBLY TIP

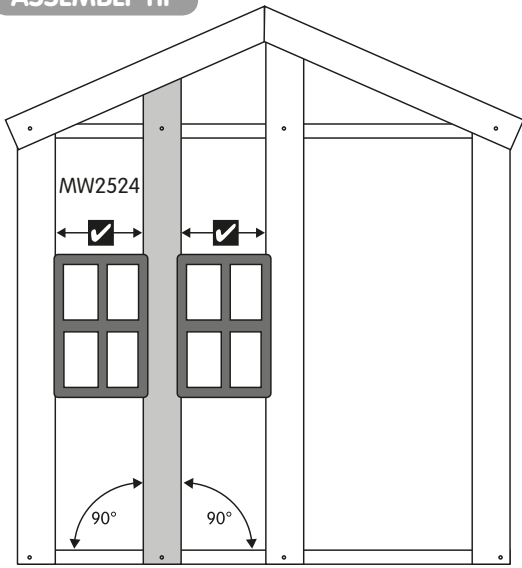

Use windows to ensure correct fixing position of MW2524

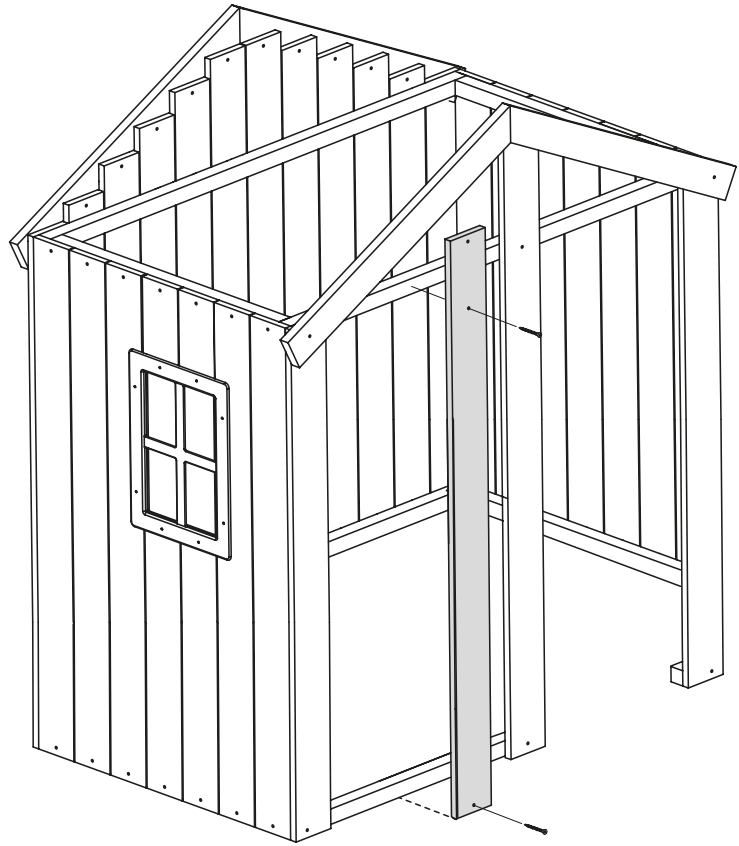

12

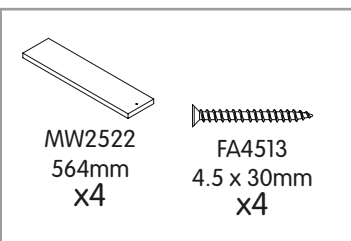

ASSEMBLY TIP

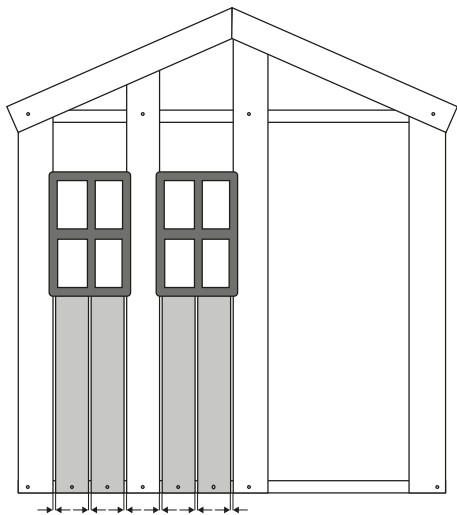

Ensure equal spacing of boards. Use windows to assist fixing only.

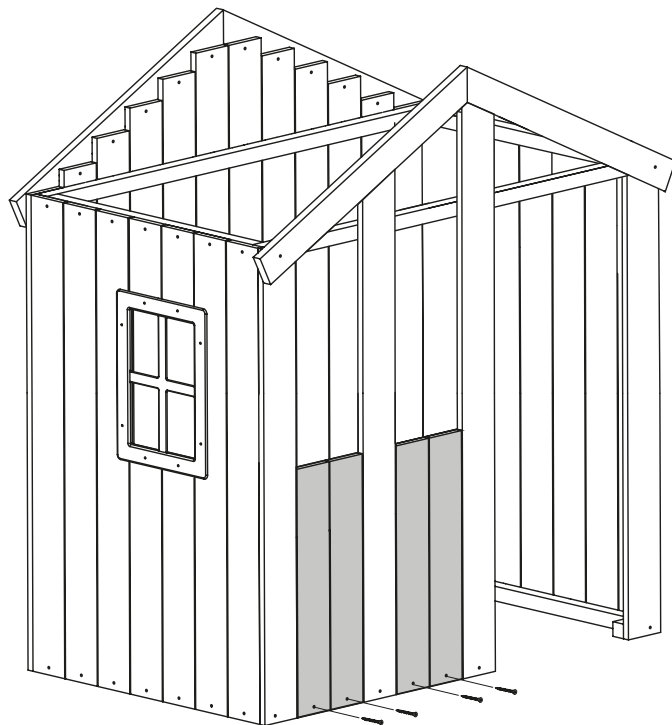

13

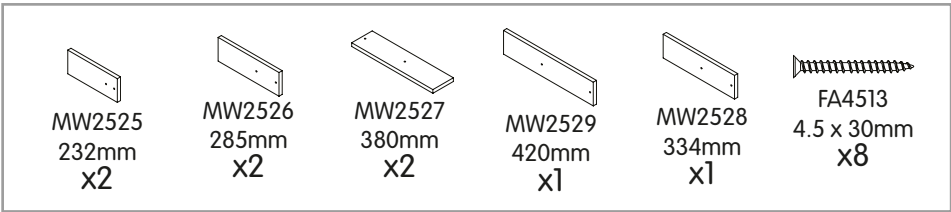

ASSEMBLY TIP

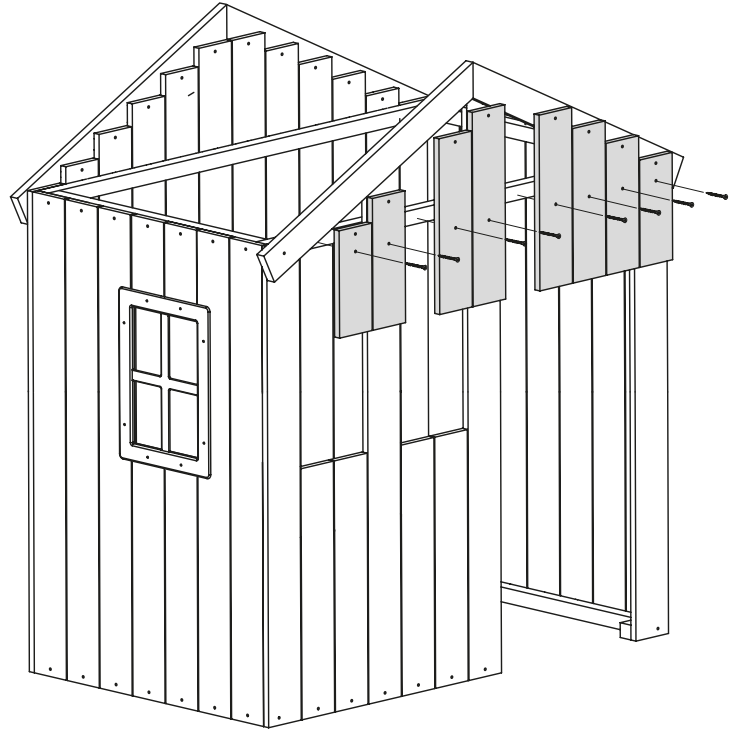
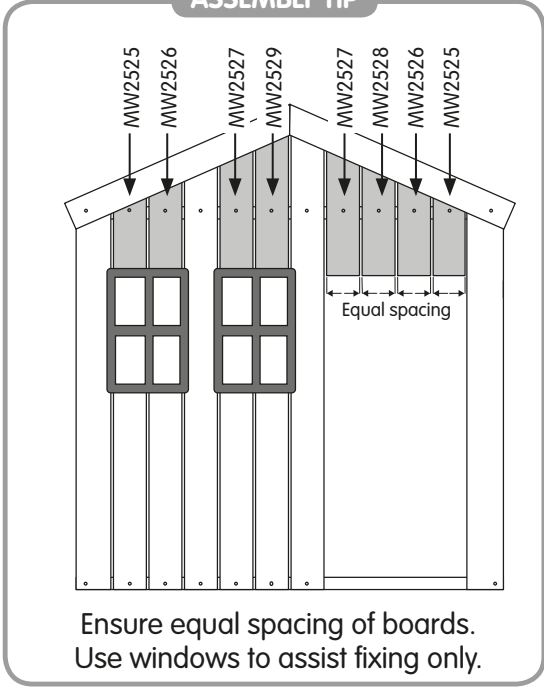

14

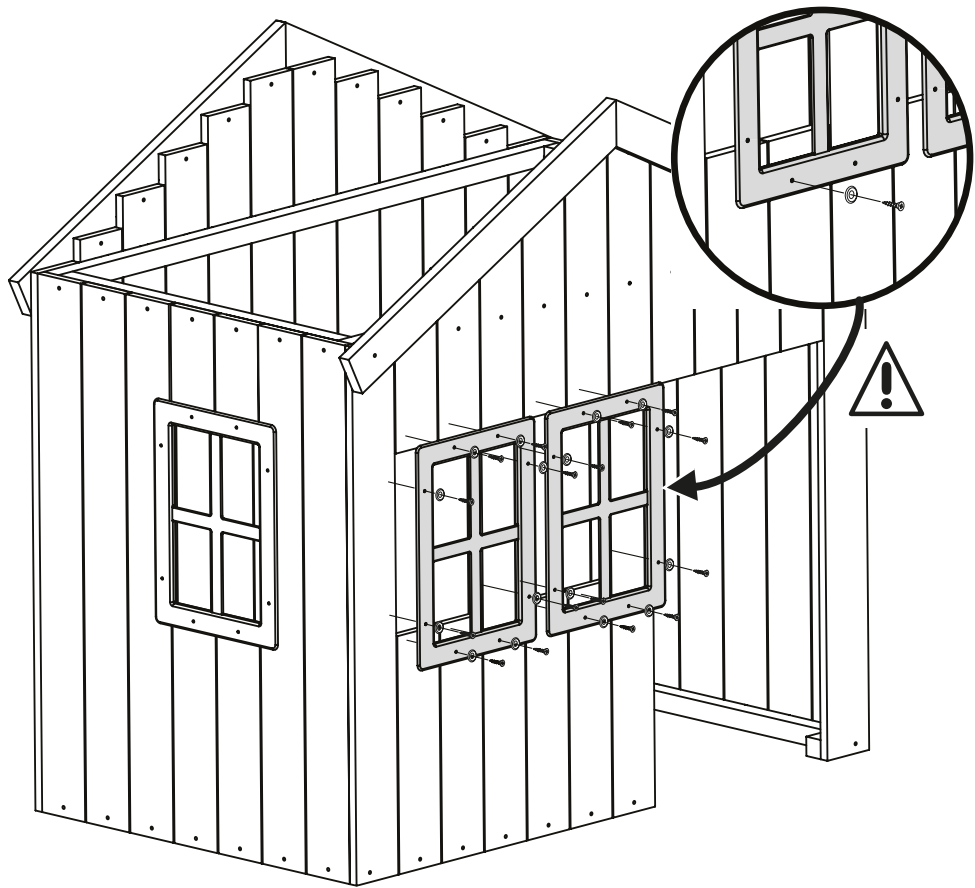
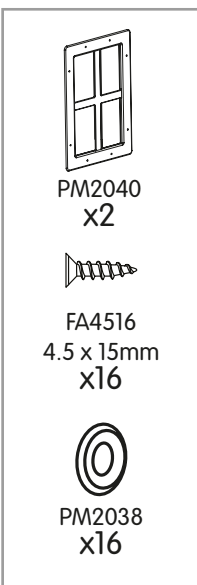

16

15

FA4513
4.5 x 30mm
x10

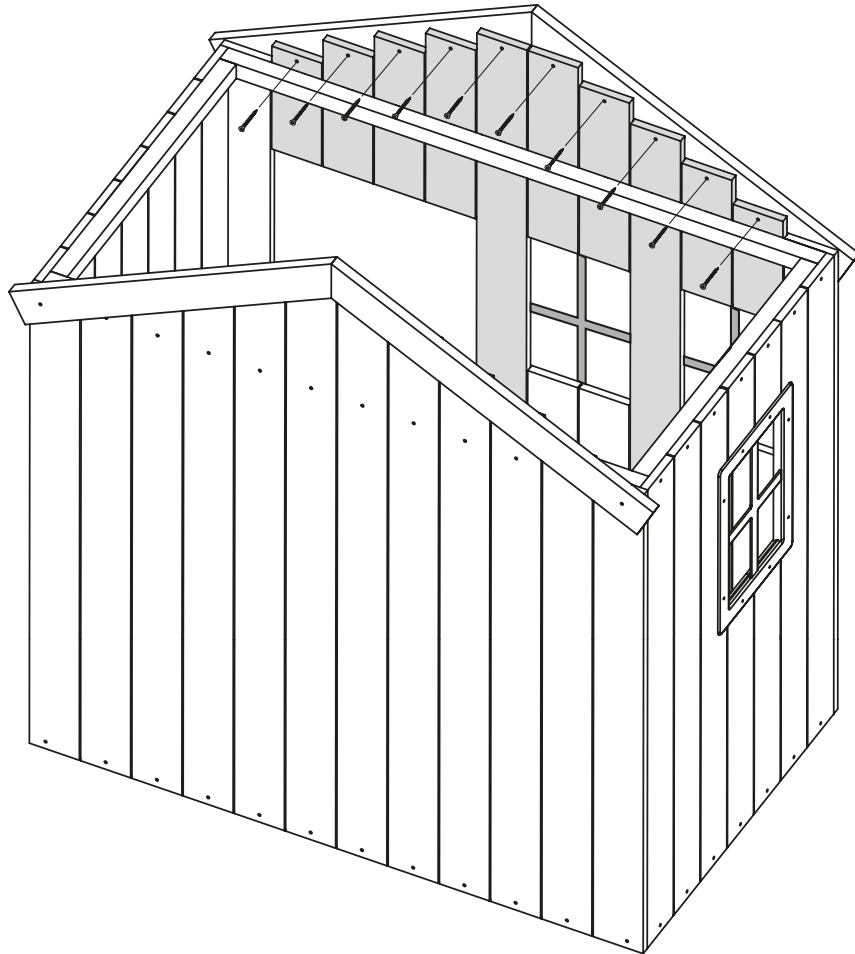

16

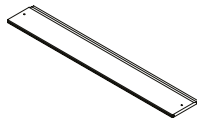

MW2515
772mm
x6

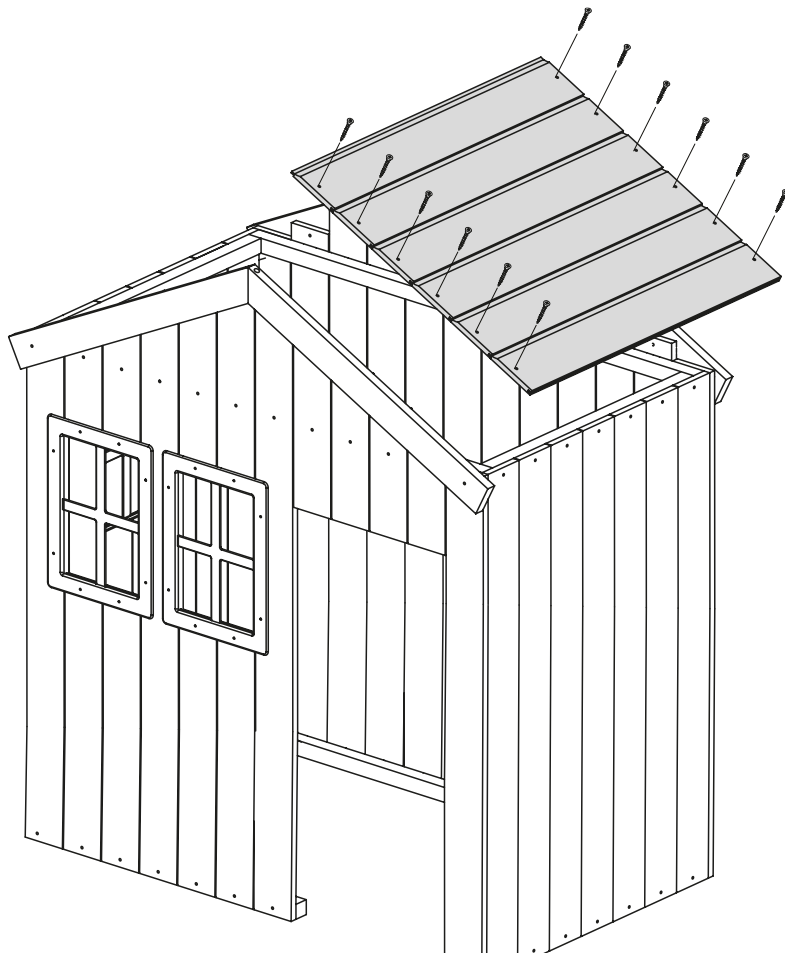

FA4513
4.5 x 30mm
x12



17

Forest Cottage

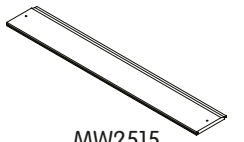
17



MW2515
772mm
x6

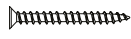

FA4513
4.5 x 30mm
x12

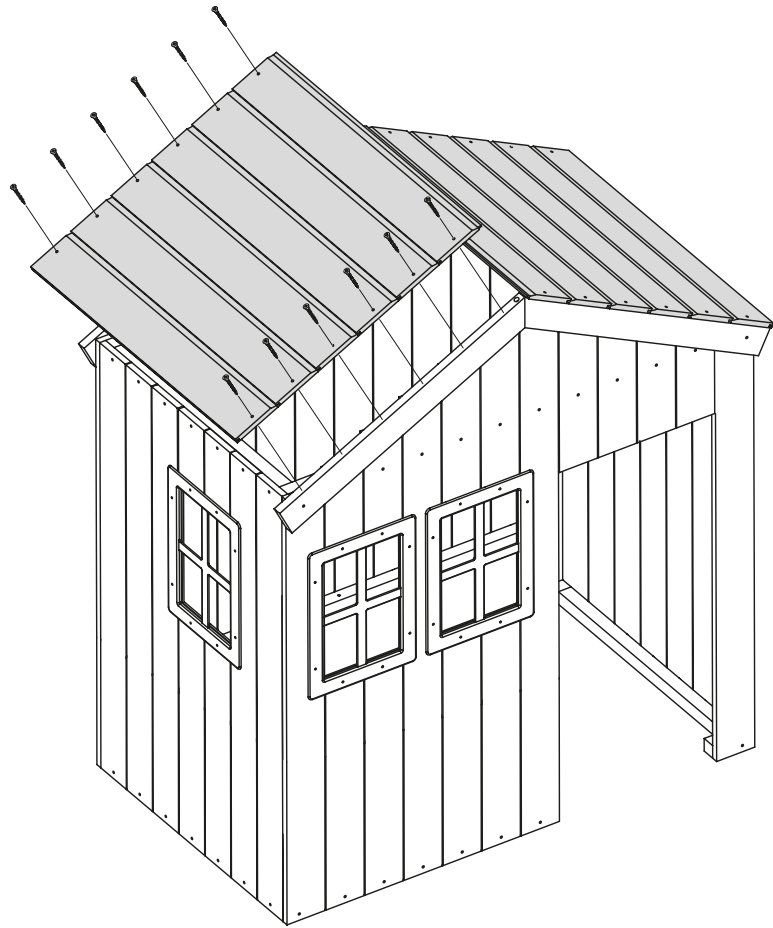
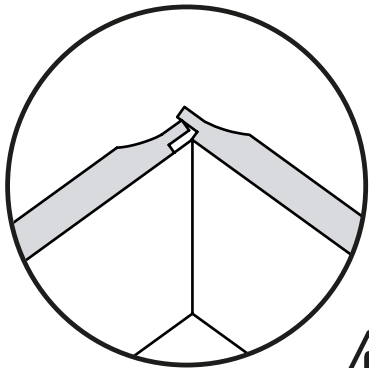

18



PM1007
Flag
x1



MW2510
Chimney Block 80mm
x1

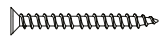

FA4517
4.5 x 40mm
x1

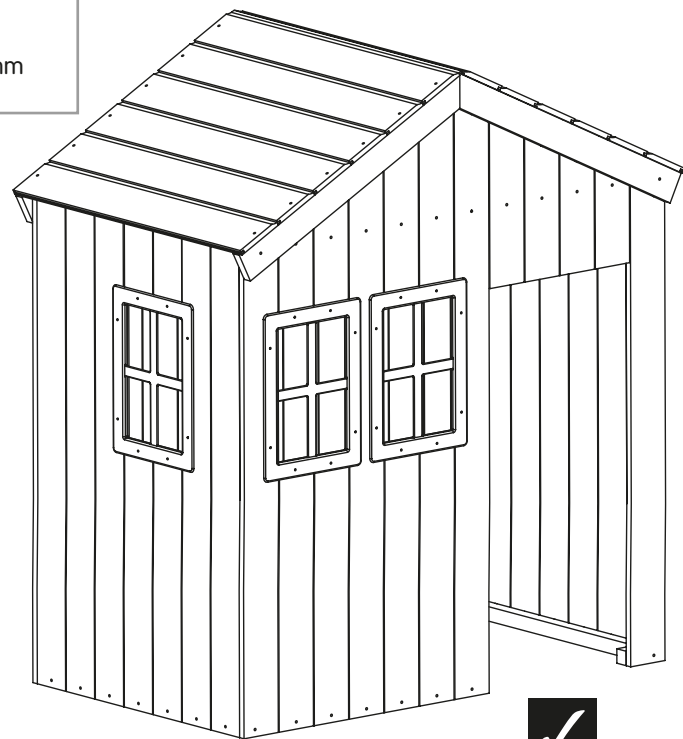
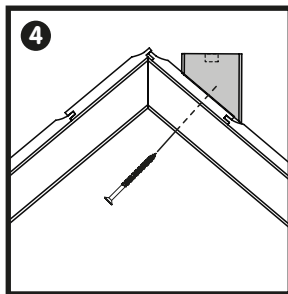
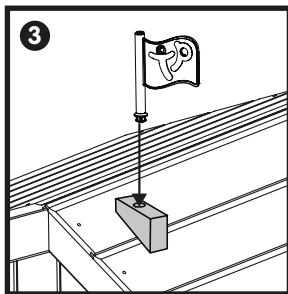
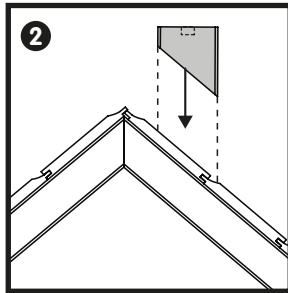
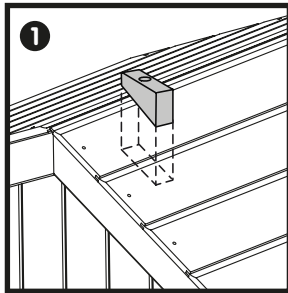

18

Forest Cottage

Pack 2 of 2: Platform

19

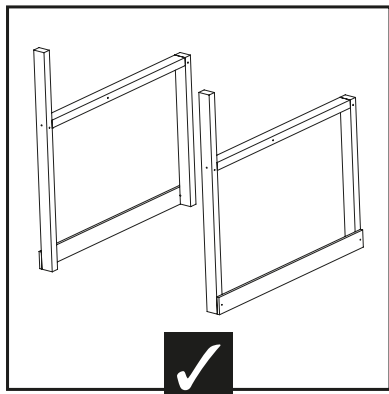
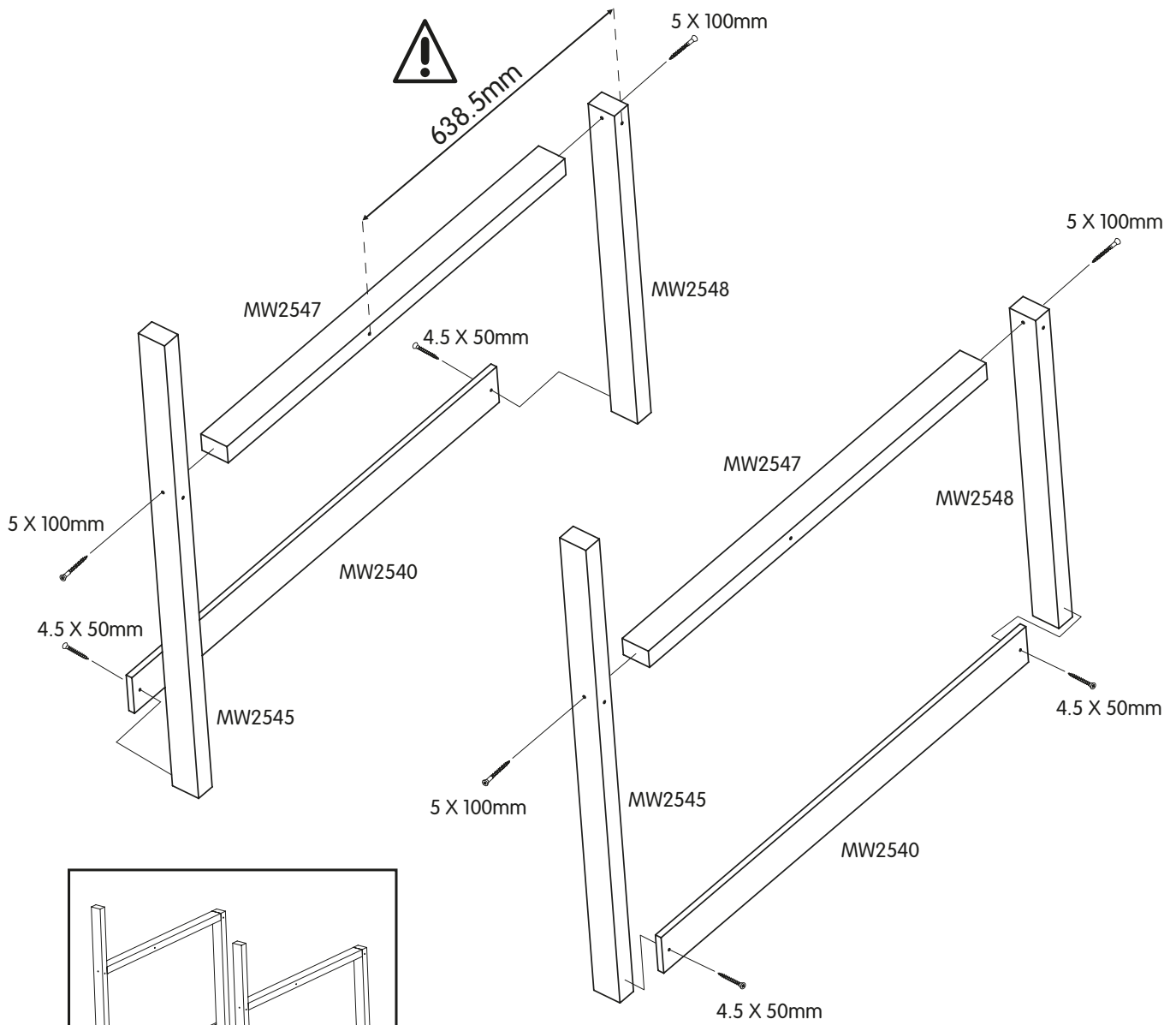
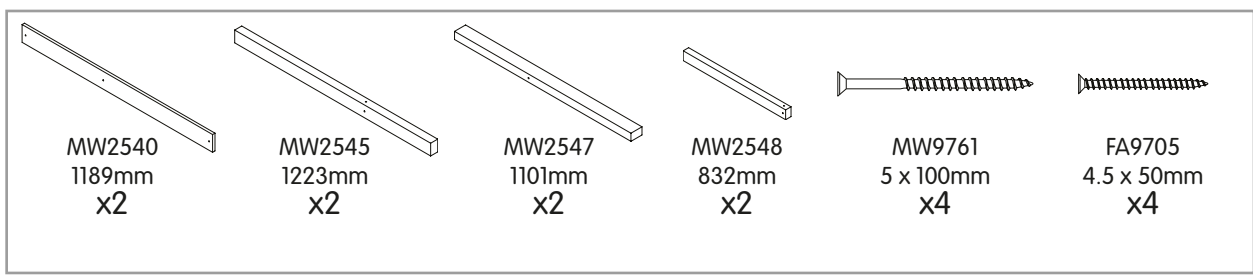

19

20

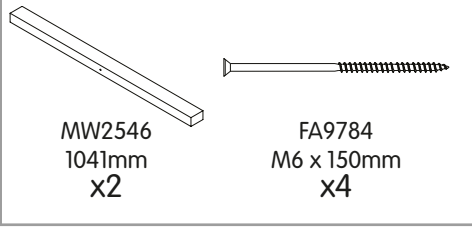

x4

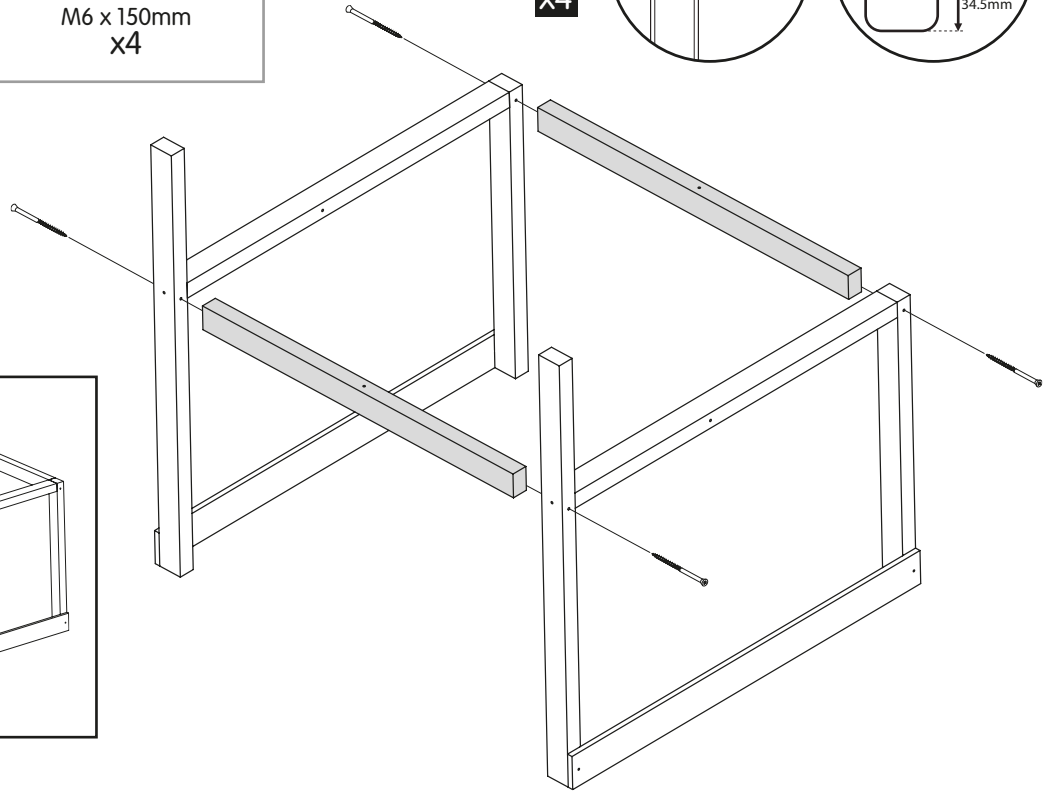
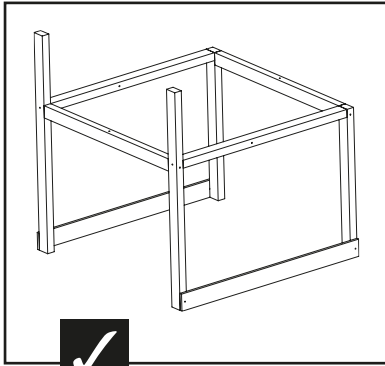
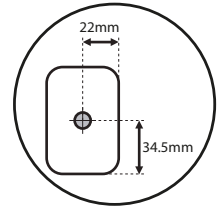
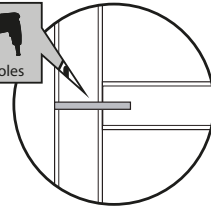

21

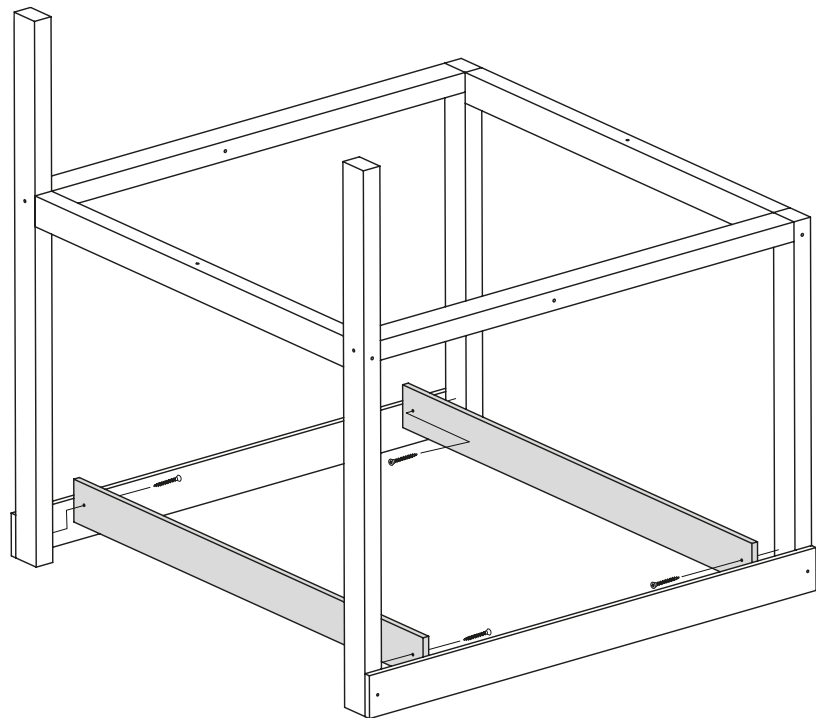
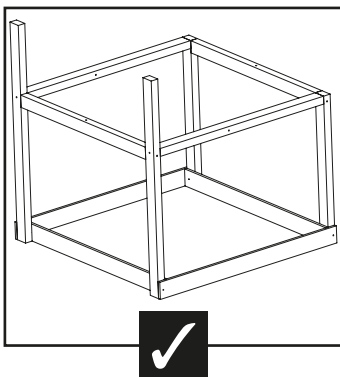
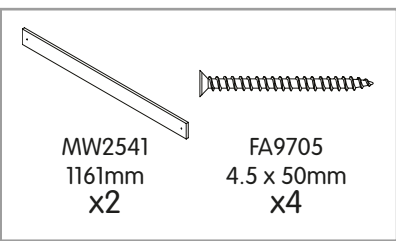

22

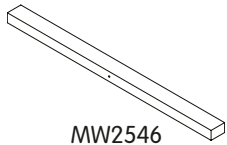

MW2546
1041mm
x1

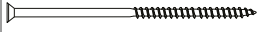

FA9784
M6 x 150mm
x2

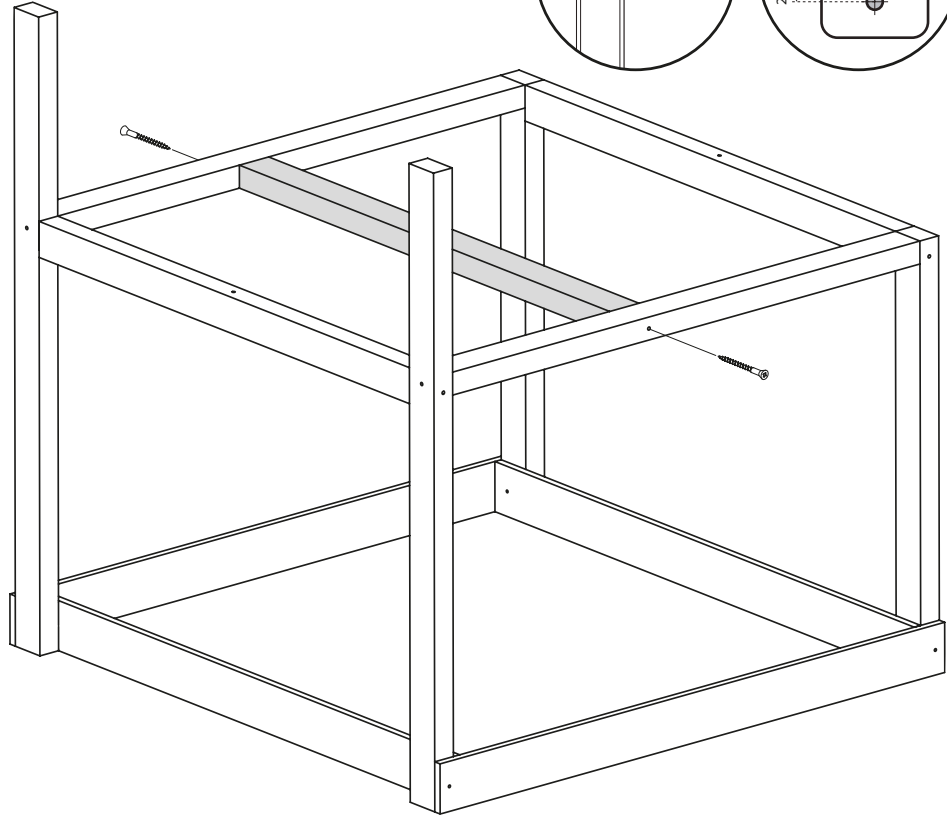
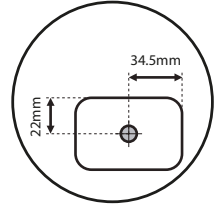
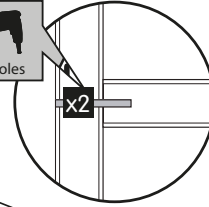

23

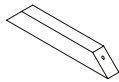

MW0169
294mm
x8

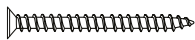

FA9705
4.5 x 50mm
x16

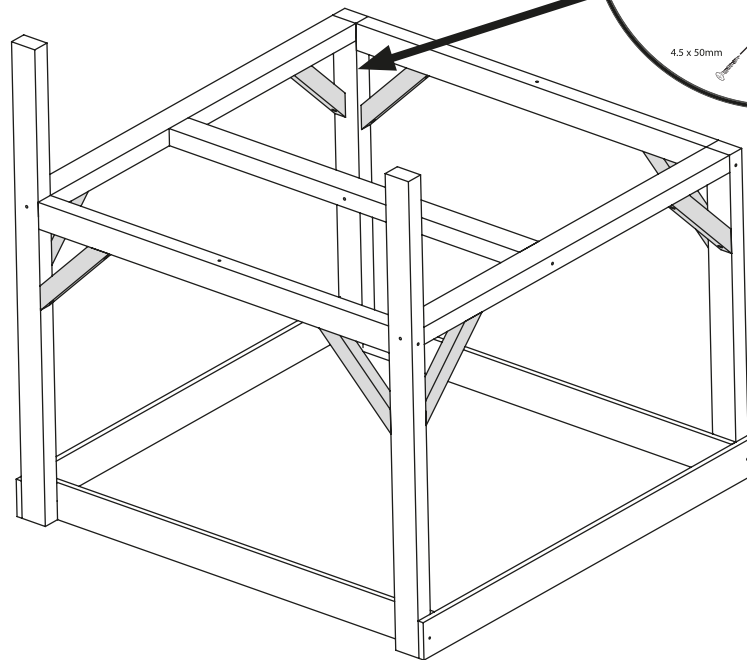
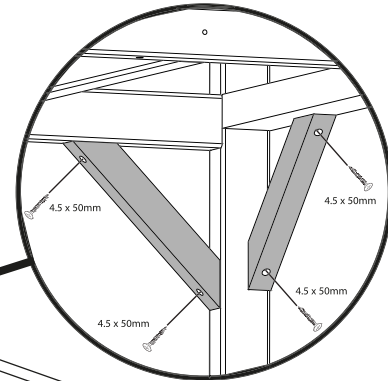
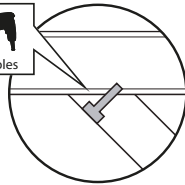

24

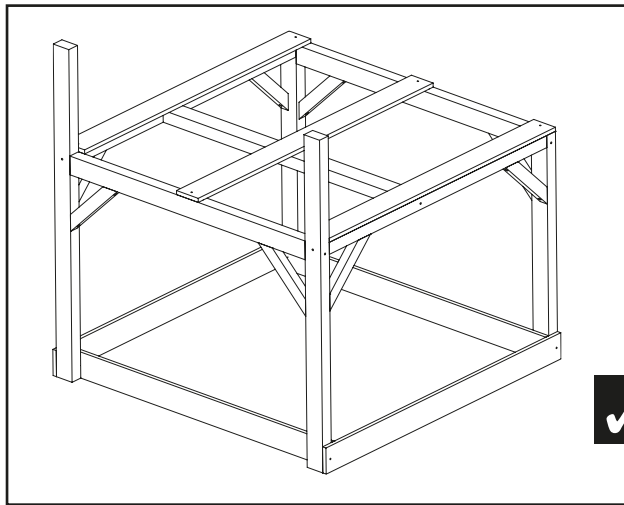
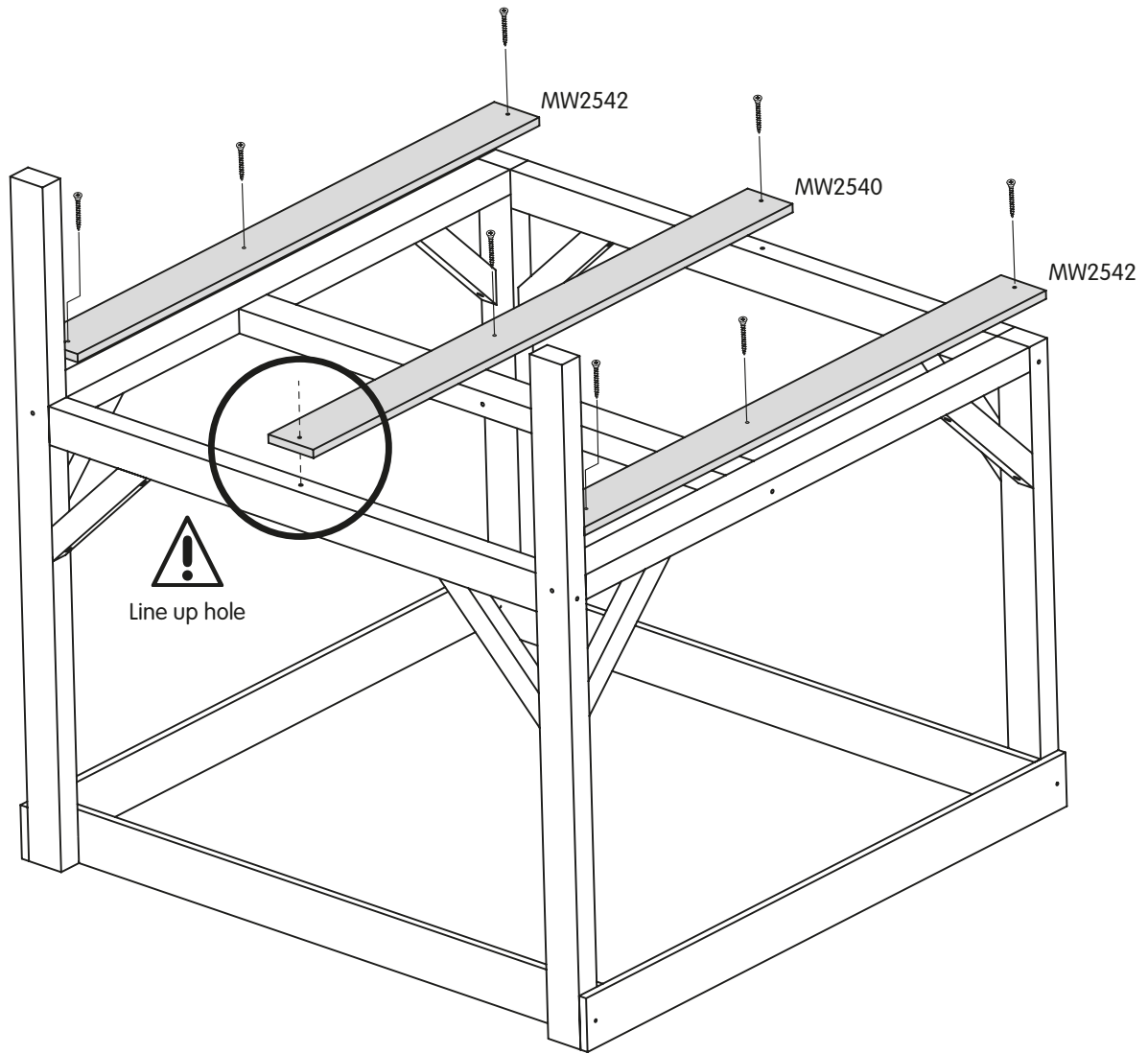
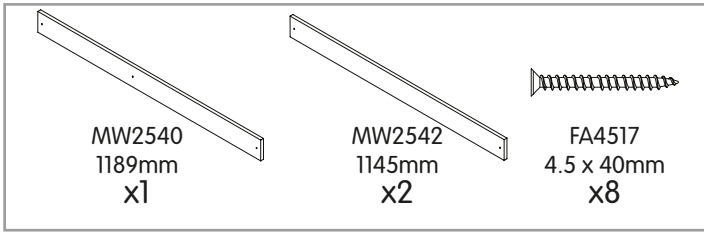

25

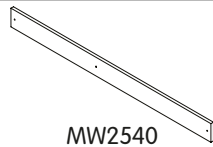

MW2540
1189mm
x8

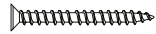

FA4517
4.5 x 40mm
x24

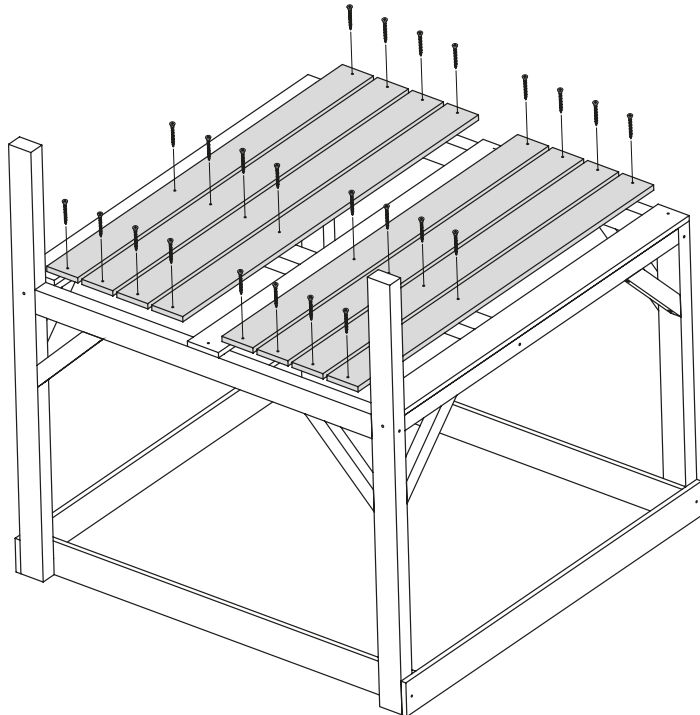

ASSEMBLY TIP

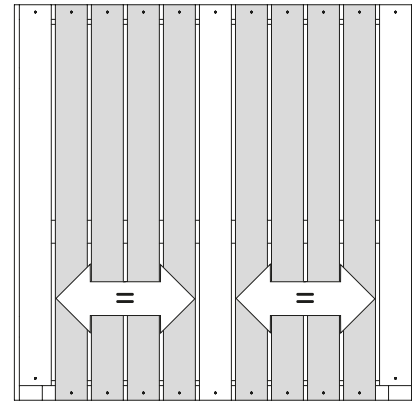

⚠ Space boards evenly.



26

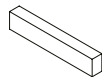

MW2549
376mm
x1

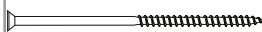

FA9784
M6 x 150mm
x1

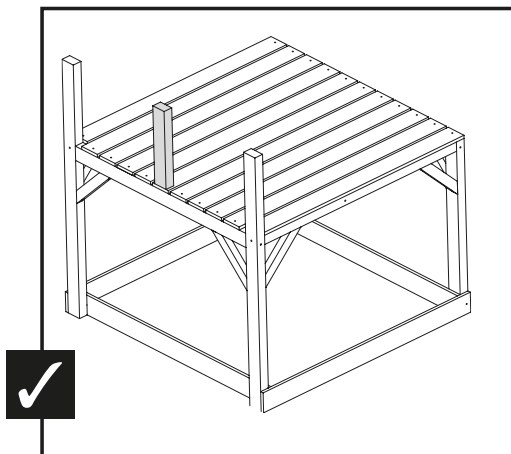
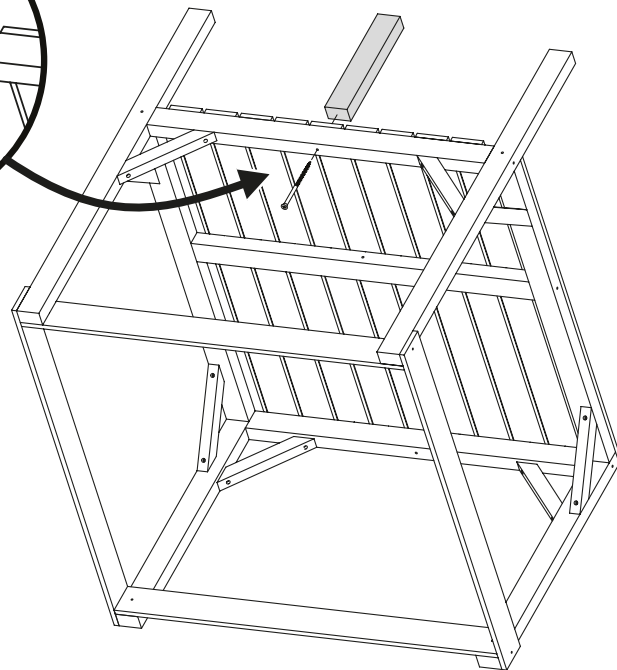
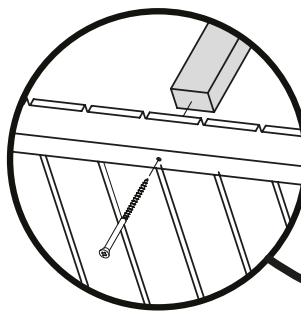
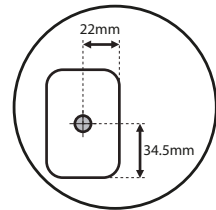
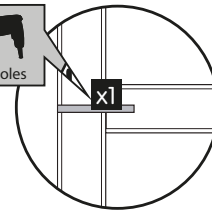

23

27

Build Option: With NO Slide

MW2543
1194mm
x1

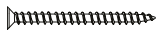
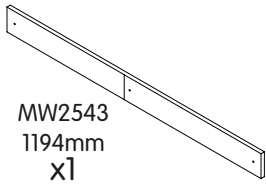

FA9705
4.5 x 50mm
x3

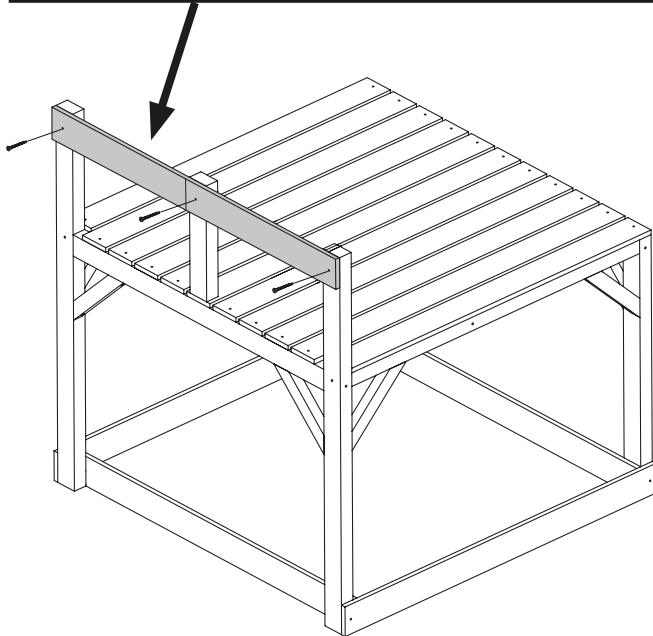
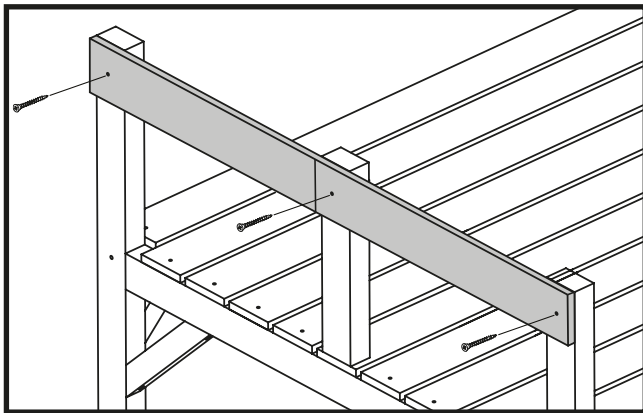

Build Option: With Slide

MW2543
1194mm
x1

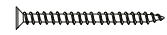
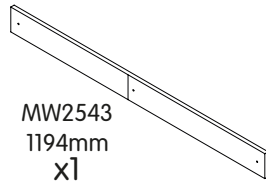

FA9705
4.5 x 50mm
x2

TP968 Wavy Slide
- Optional Purchase

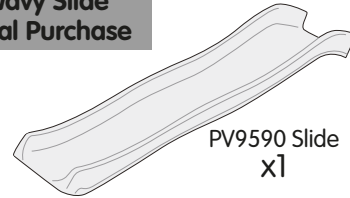

PV9590 Slide
x1

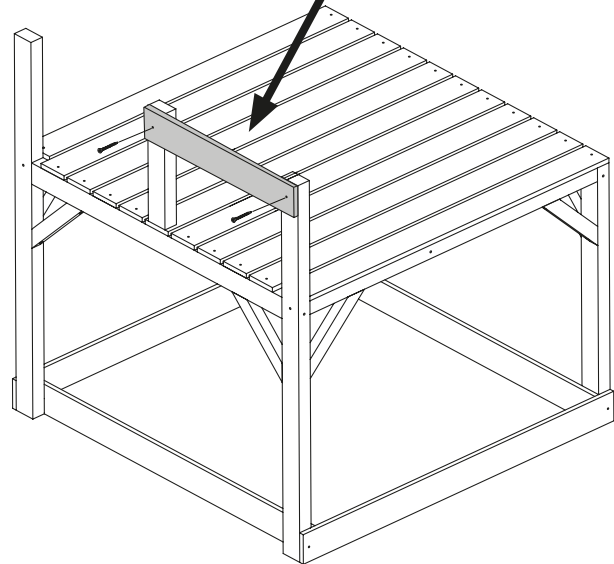
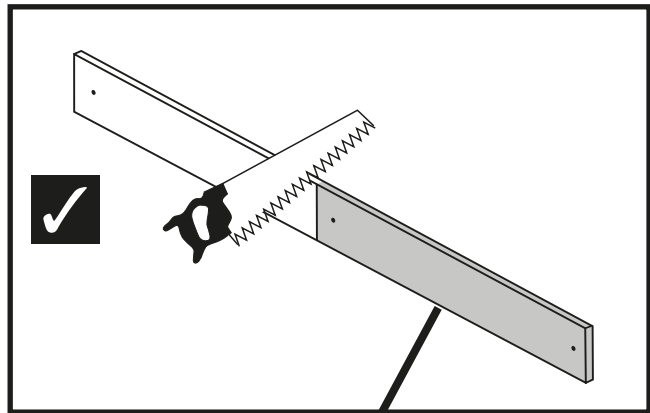

ASSEMBLY TIP

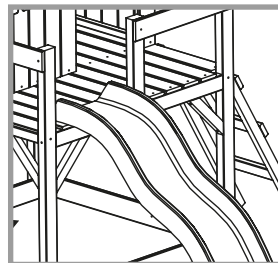

Note:
Slide to be fixed at
Stage 32

28

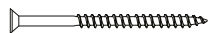

FA4521
5 x 80mm
x6

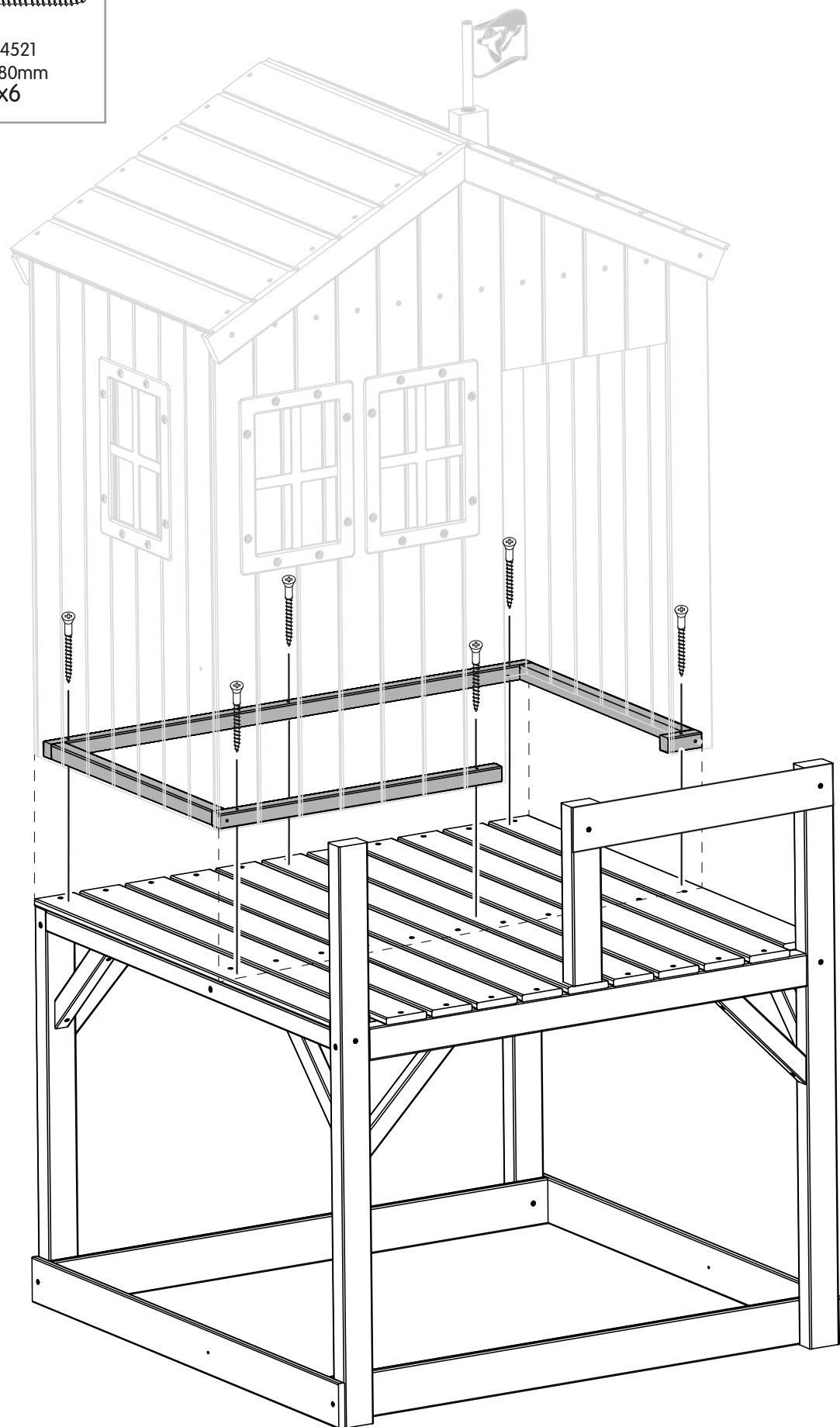



MW2544
583mm
x1

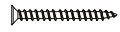

FA4517
4.5 x 40mm
x1



FA5164
M6 x 35mm
x1



FA5095
M6 Washer
x1



FA5192
M6 Dome Nut
x1

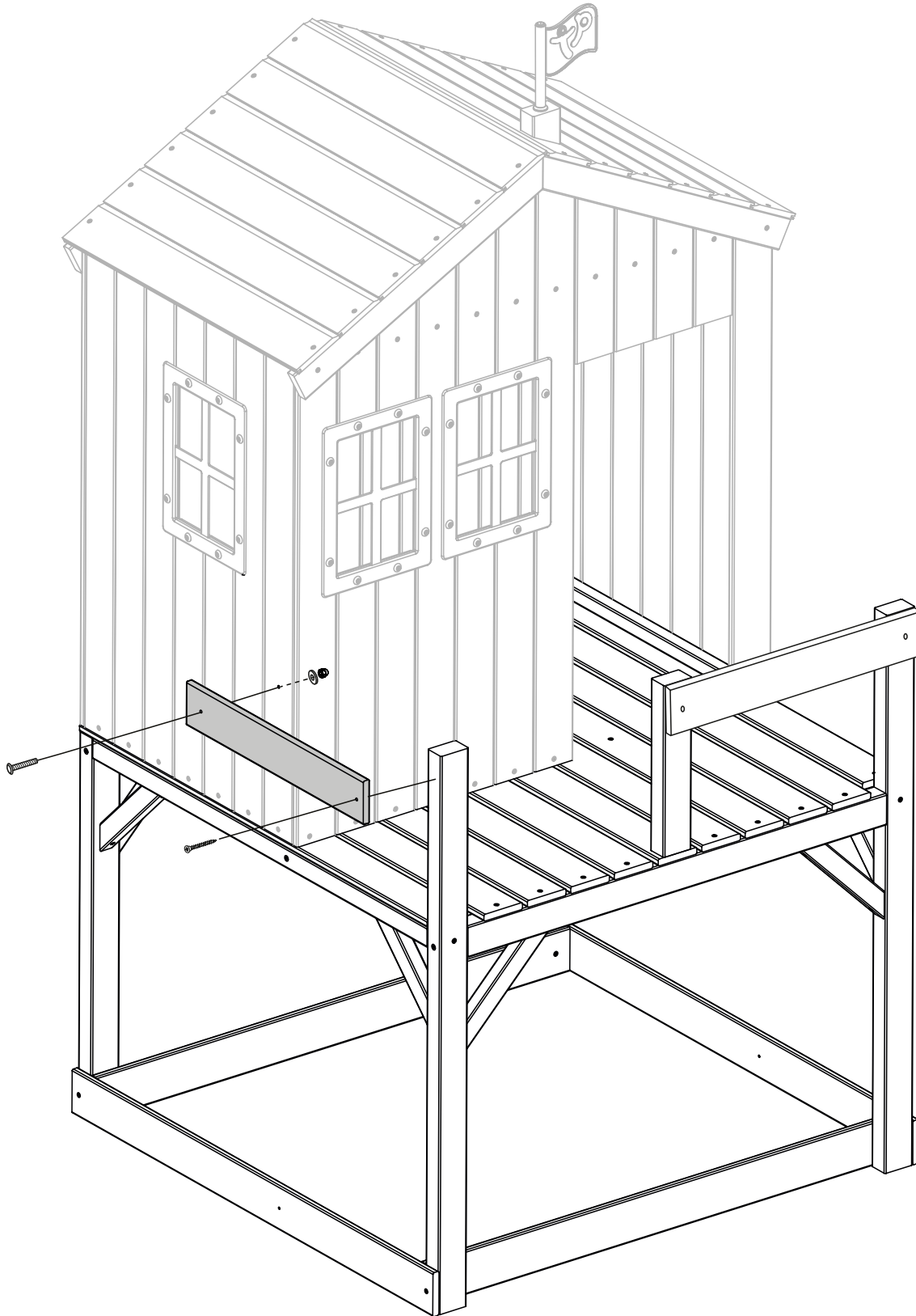

30

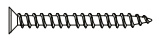

FA4517
4.5 x 40mm
x12



MW0172
997mm
x2

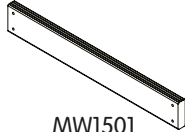

MW1501
414mm
x3

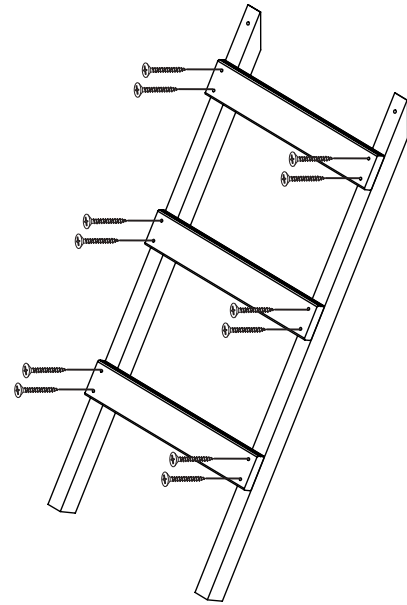
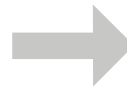
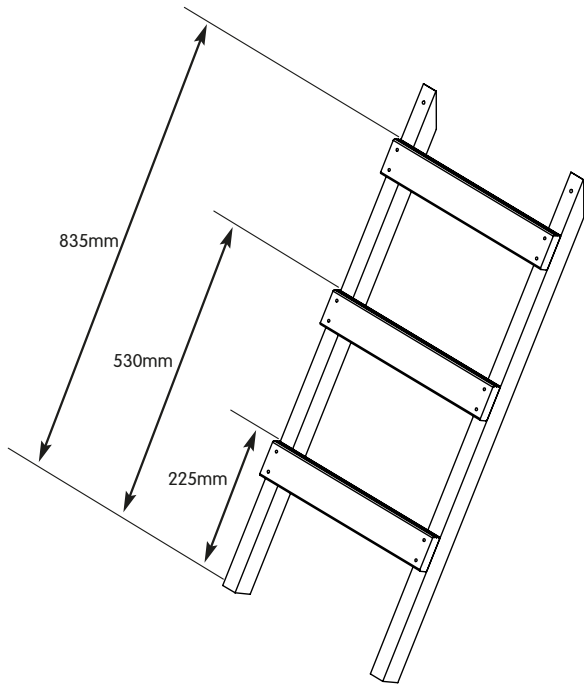

31

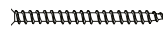

FA9705
4.5 x 50mm
x2

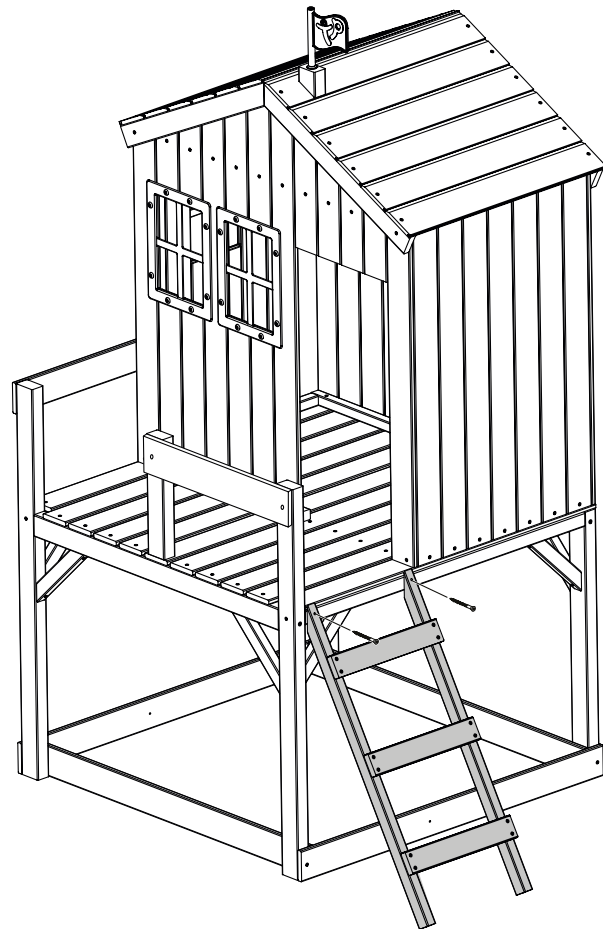
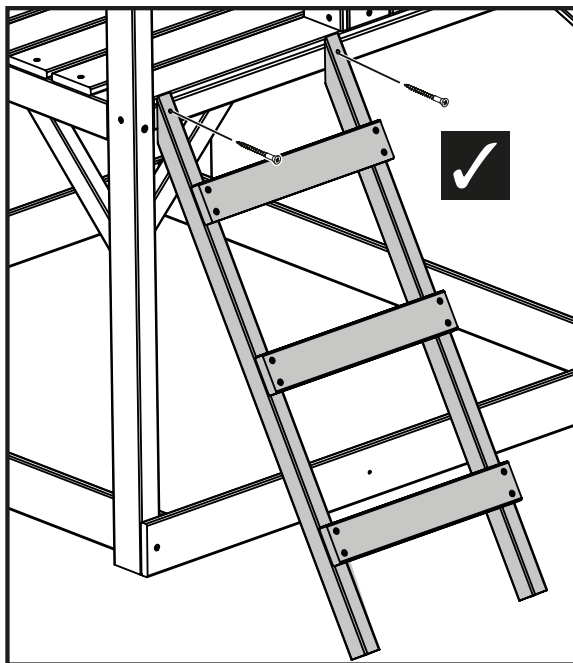

32

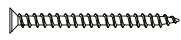

FA9705
4.5 x 50mm
x2

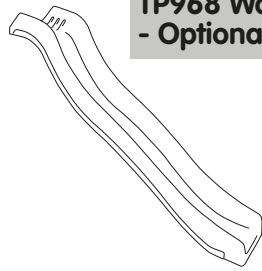

TP968 Wavy Slide
- Optional Purchase

PV9590
Slide
x1

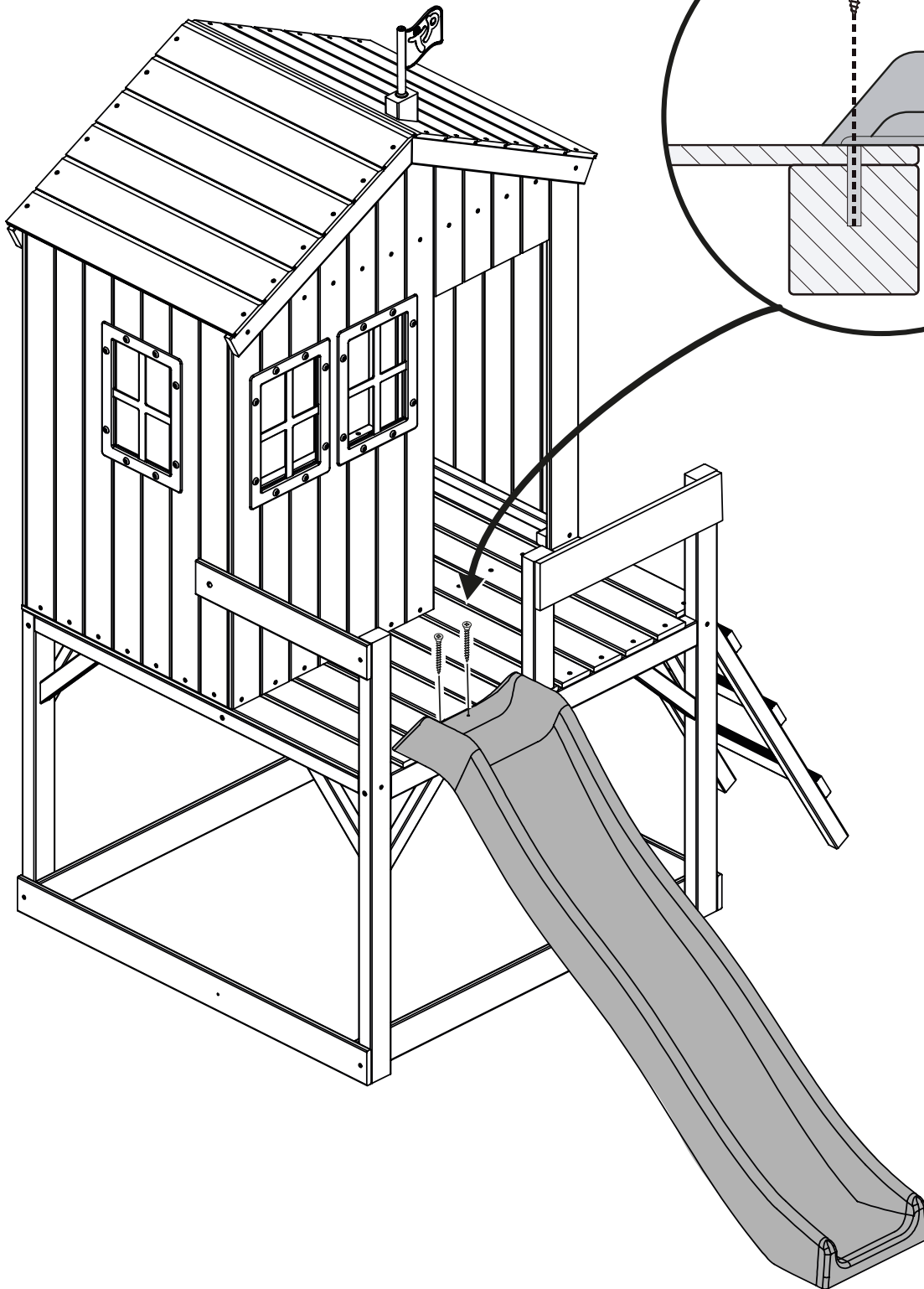

33

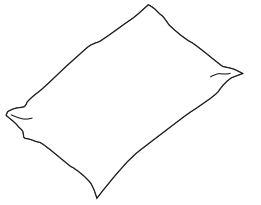

FB9985
Sandpit Liner
x1

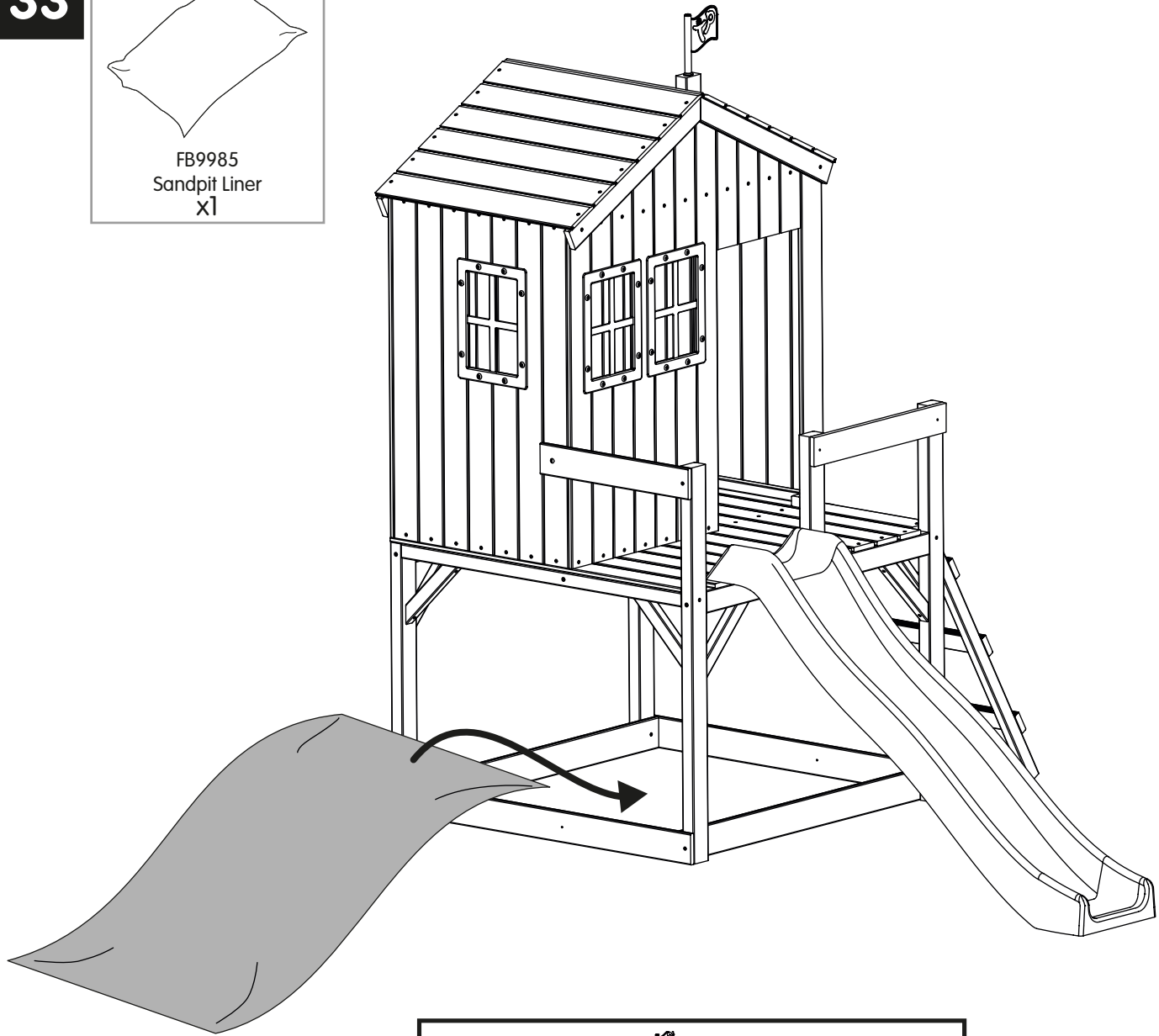

34



PM2001
Ground Peg
x2

FA9768
5 x 60mm
x2

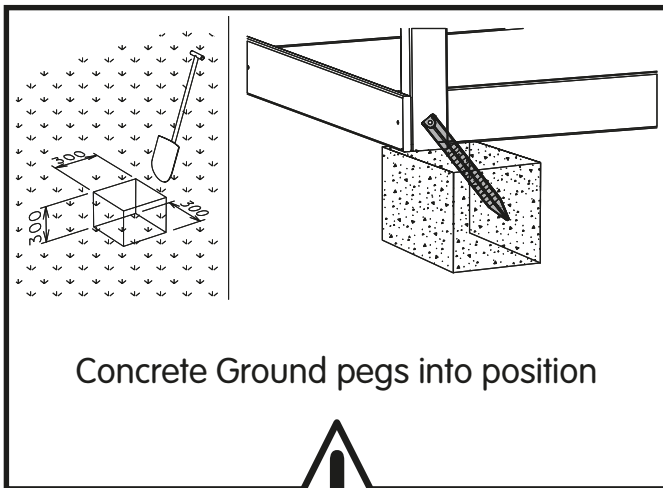
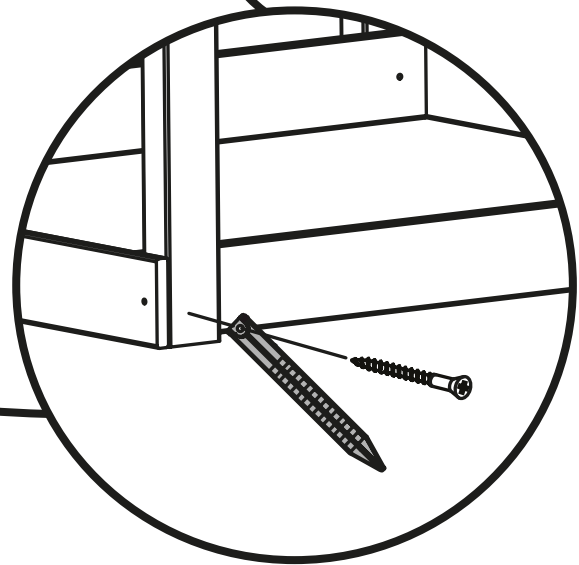
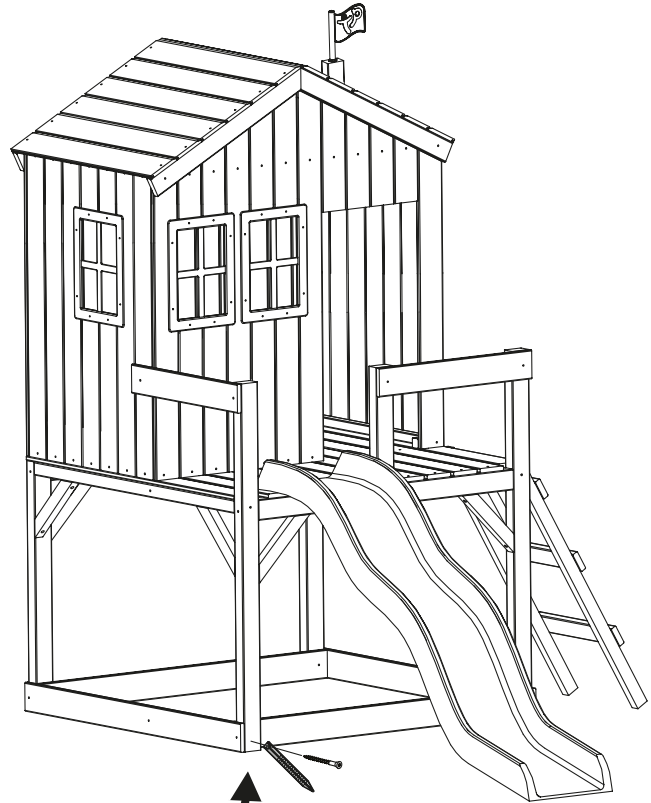
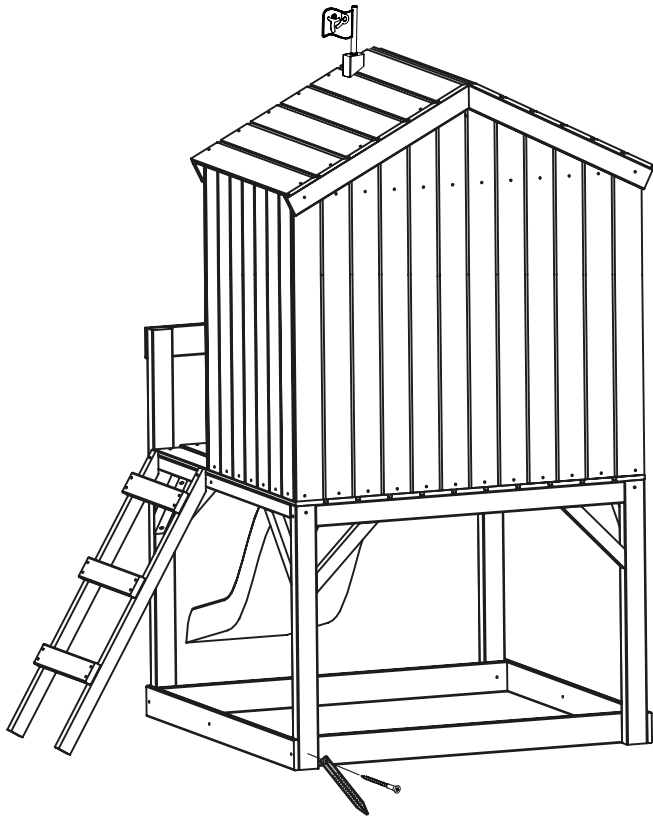

Concrete Ground pegs into position



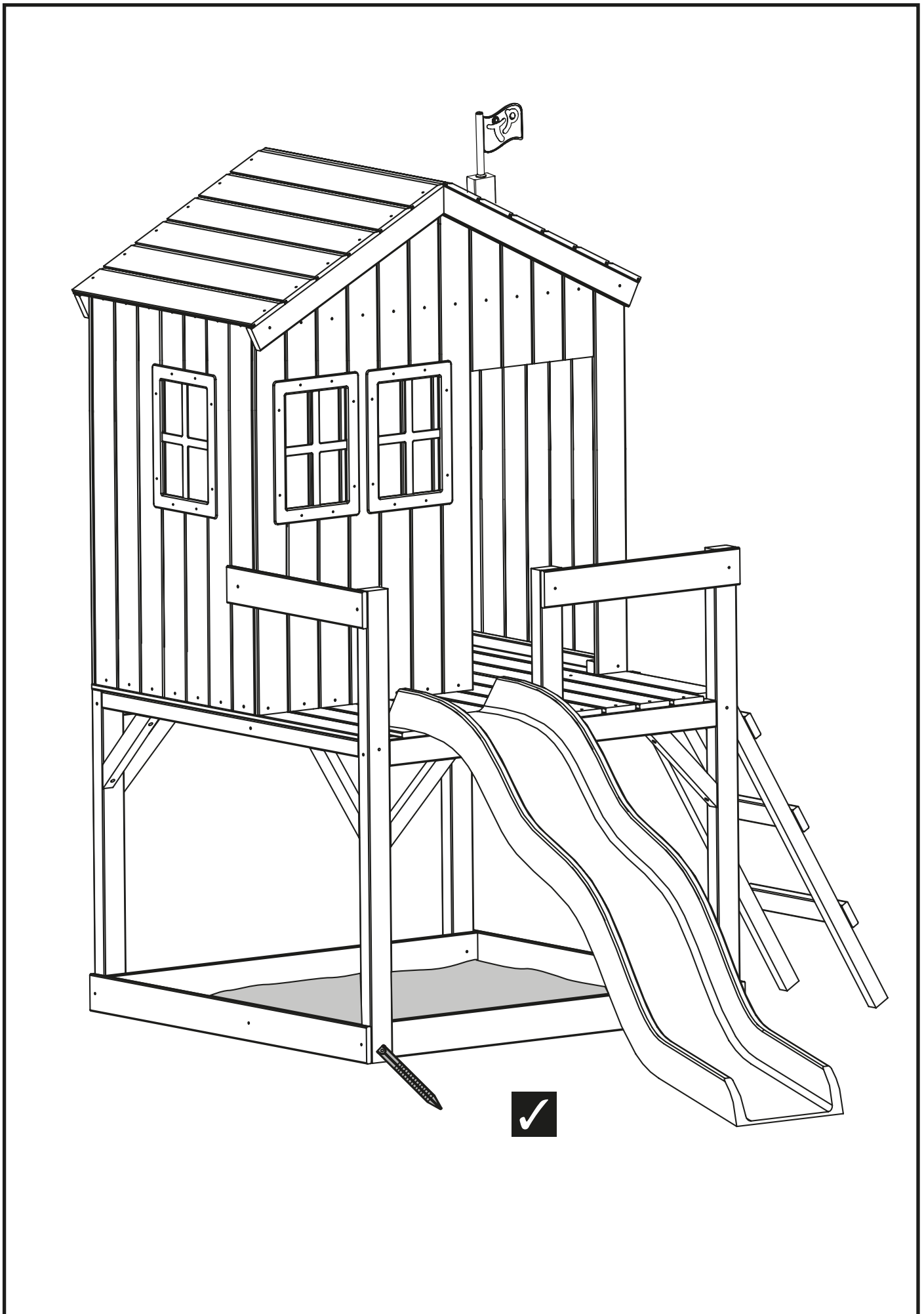

Safe Play Area

**TP351 Forest Cottage
(with Slide)**

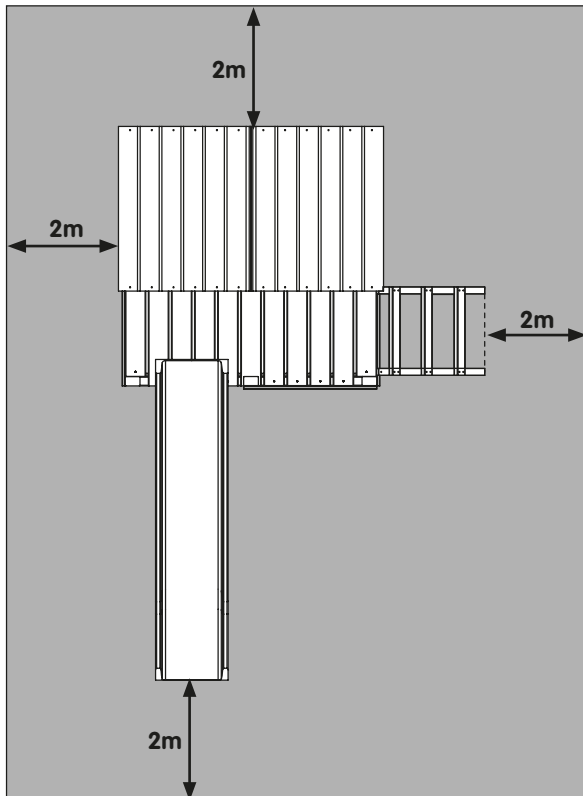

**TP351 Forest Cottage
(no Slide)**

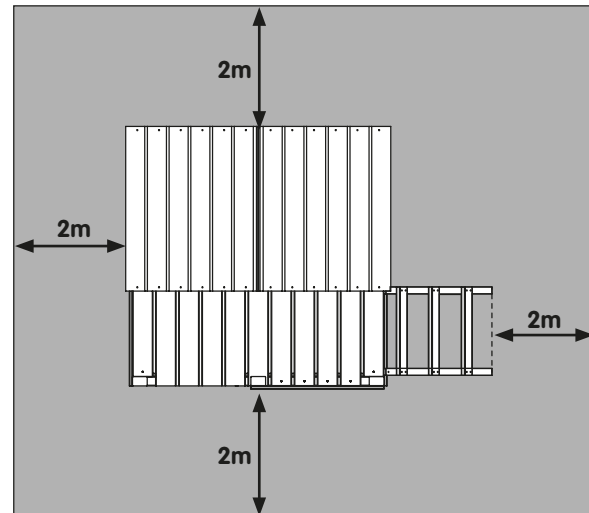

Recommended Free Space:

The Safe Play Area refers to the zone extending 200cm (2 metres) beyond the toy on all sides and 700cm (7 metres) above the toy. The Safe Play Area must be free from all structures, landscaping, trees and branches, rocks, wires, sprinkler heads and other similar obstacles to safe play. Children can be seriously injured running or colliding into such obstacles.

Aire de sécurité recommandée:

L'aire de sécurité se réfère à la zone située dans un rayon de 2 m tout autour du jeu, y compris l'espace situé au-dessus de ce dernier. L'ajout d'accessoires est susceptible d'étendre cette aire de sécurité. La surface au sol doit être bien plane. Installé sur un terrain en pente, ce jeu pourra pencher ou s'endommager. Les composants seront alors soumis à des tensions plus importantes, ce qui risque de diminuer leur durée de vie. L'aire de sécurité ne doit pas comporter de structures, aménagements paysagers, arbres et branches, pierres, câbles, têtes d'arrosage ou autres obstacles susceptibles d'empêcher les enfants de jouer en toute sécurité. Les enfants pourraient heurter ces obstacles en courant ou en se balançant et ainsi se blesser grièvement.

Area di gioco sicura raccomandata:

L'Area di giuoco sicura si riferisce alla zona che si estende per 2 m su tutti i lati oltre l'insieme da gioco, incluso lo spazio al di sopra dell'apparato. Gli accessori aggiuntivi possono estendere le dimensioni dell'Area di gioco sicura. La superficie del terreno deve essere in pari. Installando l'insieme da gioco sul terreno in pendenza, può inclinarsi o 'stirarsi'. Ciò sottoporrebbe tutti i componenti a sforzo addizionale, e potrebbe comprometterne la durata. L'Area di gioco sicura deve essere libera da strutture, variazioni del terreno, alberi e rami, pietre, fili metallici, testine per annaffiare e tutto quanto esporrebbe a rischio la sicurezza del gioco. Correndo contro questi ostacoli, o urtandovi durante l'oscillazione, i bambini potrebbero ferirsi seriamente.

Safe Play Area

Área Segura de Juego recomendada:

El Área Segura de Juego se refiere a la zona que se extiende hasta 2m desde los juegos todo alrededor, incluyendo el espacio encima del aparato. Accesorios adicionales pueden aumentar el tamaño del Área Segura de Juego. La superficie del suelo debe ser uniforme. Si instala sus juegos sobre un terreno con declive, har- que se inclinen o se "arruinen". Esto coloca tensión adicional sobre todos los componentes y puede acortar su vida útil. El Área Segura de Juego debe estar libre de todo tipo de estructuras, arquitectura paisajista, árboles y ramas, rocas, cables, boquillas de aspersores y cualquier otro elemento que pueda obstaculizar el juego seguro. Los niños pueden herirse gravemente con estos obstáculos al correr o columpiarse.

Empfohlene sichere Spielfläche:

Die sichere Spielfläche erstreckt sich an allen Seiten 2 m über das Spielgerät hinaus, einschließlich Raum über dem Gerät. Zubehör kann die sichere Spielfläche erweitern. Der Boden muss eben sein. Wenn Sie das Spielgerät auf einem Hang installieren, kann es sich lehnen oder verziehen. Dadurch werden alle Teile zusätzlicher Last ausgesetzt, was zu verkürzter Lebensdauer führen kann. Im sicheren Spielraum darf sich nichts befinden, das sicheres Spielen behindern könnte wie z.B. Aufbauten, Gärten, Bäume oder Büsche, Steine, Draht, Rasensprinkler oder ähnliches. Wenn Kinder in solche Hindernisse hineinlaufen oder -schaukeln, können sie sich schwer verletzen.

Área de Actividades Segura Recomendada:

A Área de Actividades Segura Recomendada refere-se à zona que se estende por 2 m em todas as direcções à volta dos elementos de diversão, incluindo o espaço acima dos mesmos. Acessórios adicionais poderão aumentar o tamanho da Área de Actividades Segura. A superfície do terreno deve ser nivelada. A instalação do parque infantil em terreno com declives pode fazer com que este fique inclinado ou "deformado". Isto coloca tensão adicional em todas as ligações e juntas e, com o passar do tempo, faz com que estas cedam. Para que a Área de Actividades seja segura, não deverá haver outras estruturas, áreas ajardinadas, árvores e ramos, rochas, fios, aspersores ou outros obstáculos semelhantes à superfície. As crianças poderão sofrer graves ferimentos pessoais se, ao correrem ou baloiçarem, caírem de encontro a estes elementos.



Register your new TP product on line now at
[www.tptoys.com/product registration](http://www.tptoys.com/productregistration)

Thank you for purchasing this TP product. To find out all about your product guarantee and register your purchase, please visit **www.tptoys.com/productregistration**

We want to give you the very best service. By registering your purchase now, we will be able to deal with any guarantee issues very quickly and efficiently in the future. Thank you.

Your TP Guarantee Number/Product Batch No is

Designed in the UK by **Robovision Ltd t/a TP Toys**
Unit 11, Enterprise Way, Flitwick, Bedfordshire. MK45 5BX

www.tptoys.com

TP Part No: IN9794 Issue-F 11 13